



# **IDOT HMA Update 2012**

**David L. Lippert, P.E.**  
Engineer of Materials and Physical Research

**Illinois Department of Transportation**

**Illinois Asphalt Paving Association**

# PG Liquid Binder Usage



# PG Binder Used (in thousand tons)

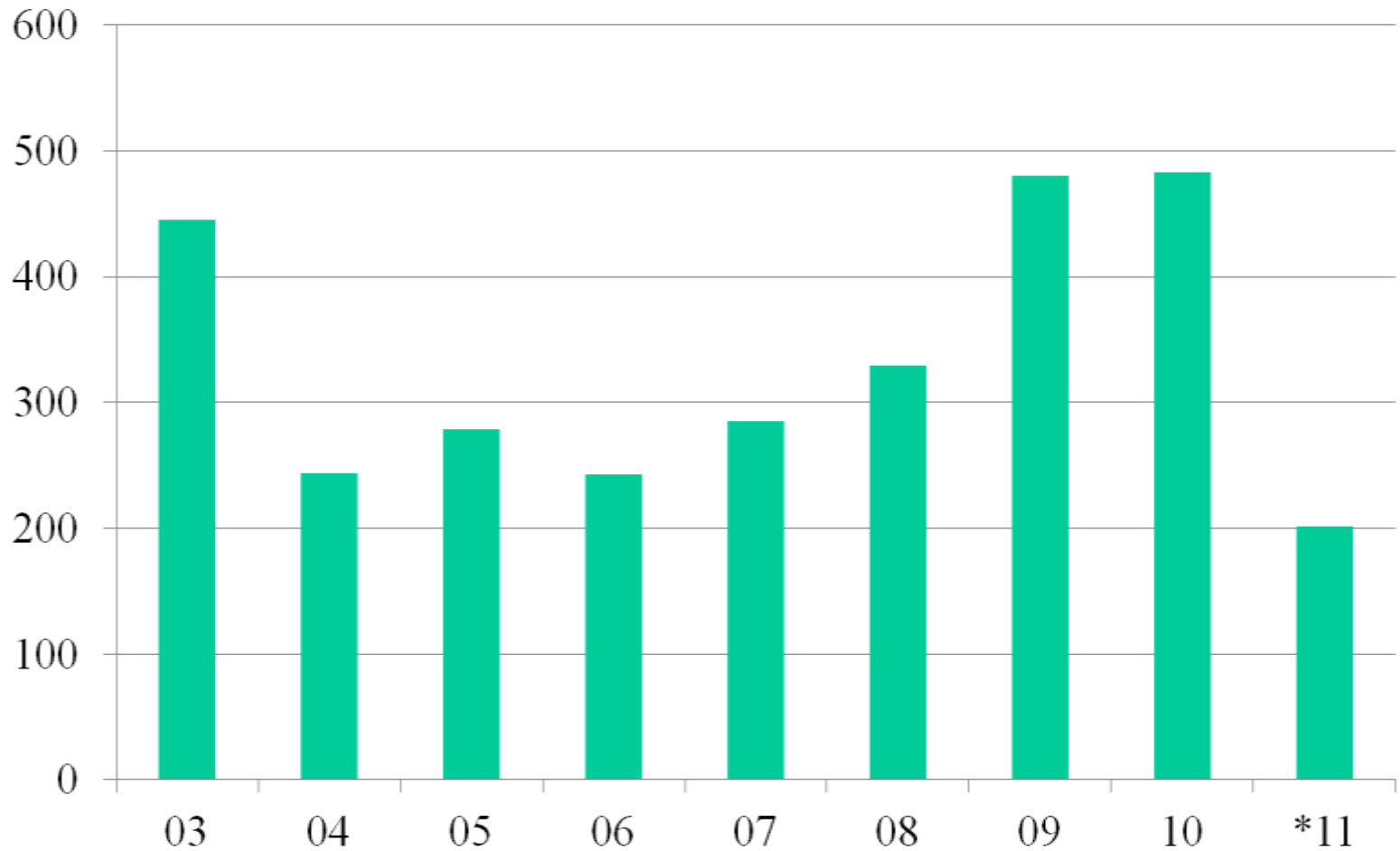

# **% Polymer Usage - 2003 to 2011**

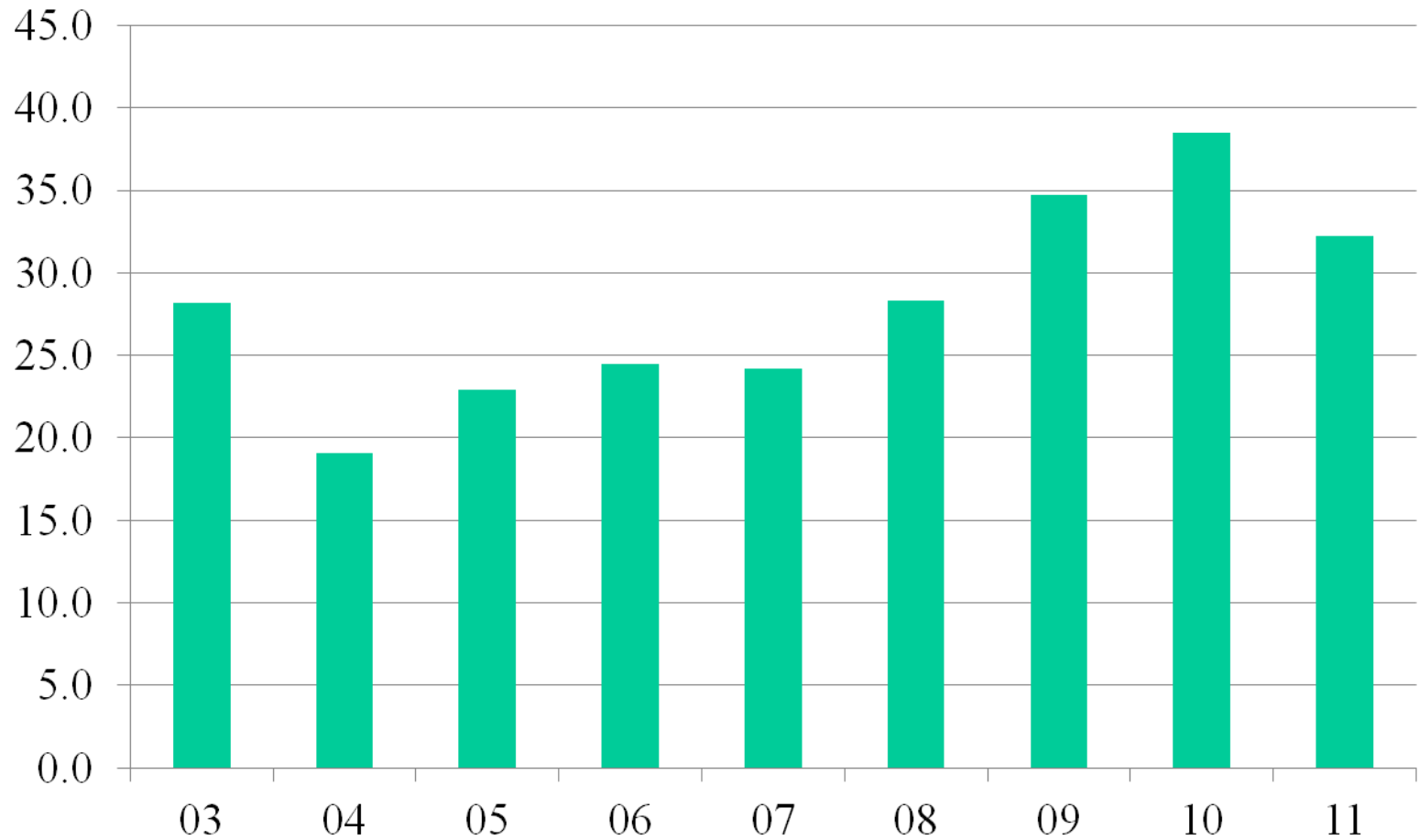

# % Grades Used - last 5 years

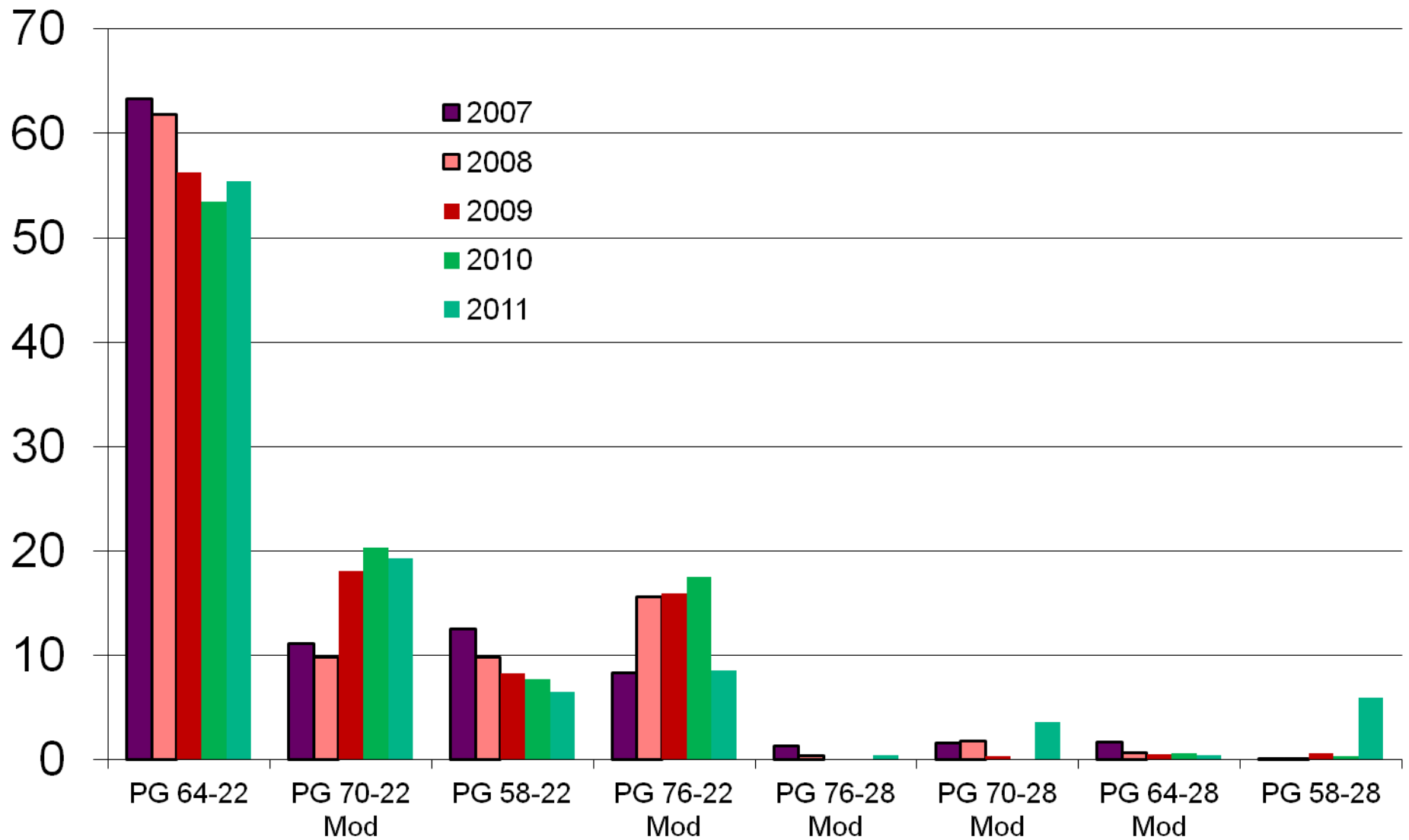

The image features a silhouette of an oil pumpjack against a warm, orange-hued sunset sky. The sun is visible as a bright point on the horizon, creating a lens flare effect. The pumpjack's structure is dark and detailed, showing the walking beam, counterweights, and various mechanical components. The overall scene is atmospheric and industrial.

# AC Price Index

# IDOT AC Price Index

- Based upon largest suppliers of previous year
- Prices submitted as of first of each month
- Average = Index
- BMPR Policy Memo 1-08.0
  - PERFORMANCE GRADED ASPHALT BINDER ACCEPTANCE PROCEDURE

# AC/Oil/Gasoline Price Comparison

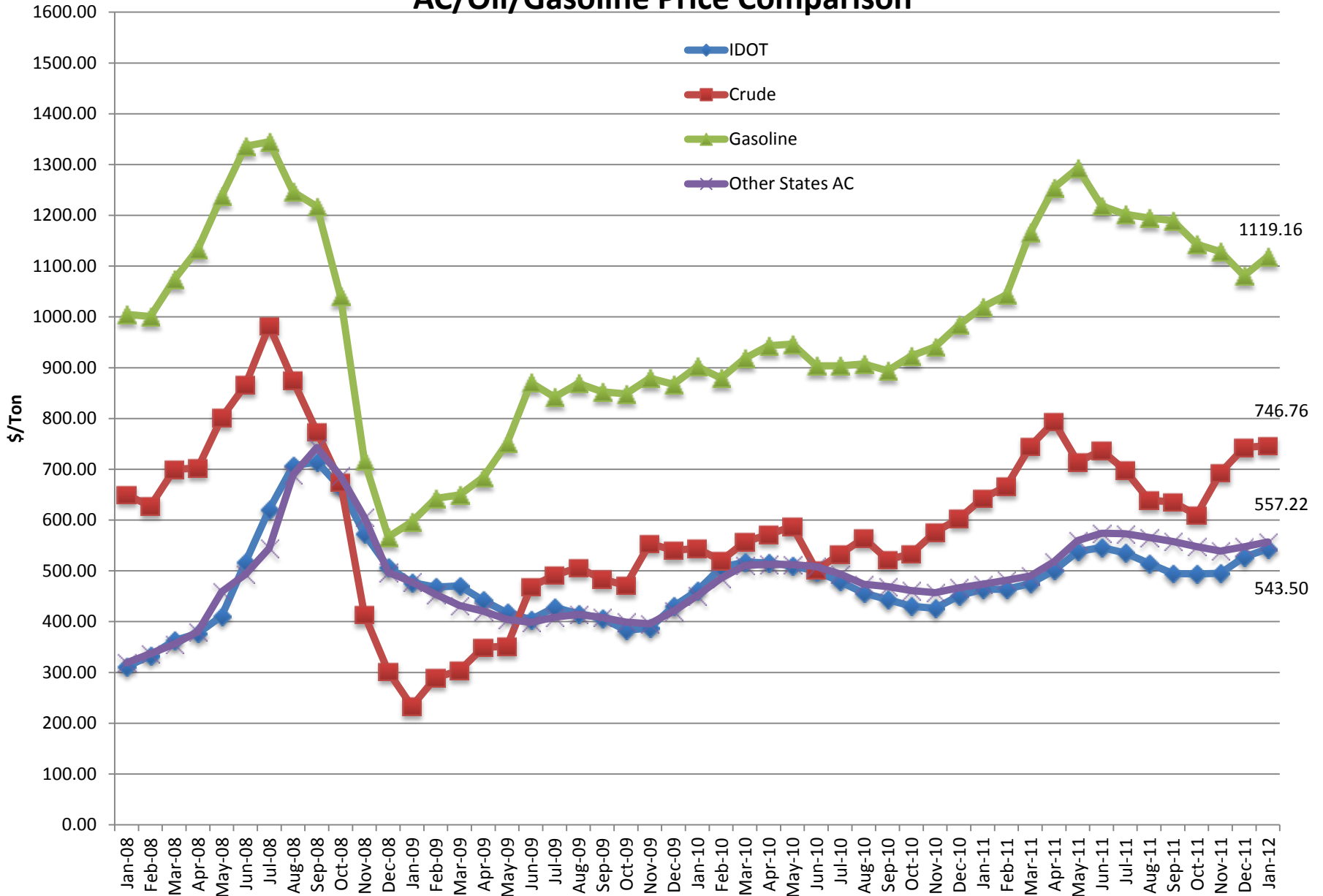



# AC/Oil/Gasoline Price Comparison

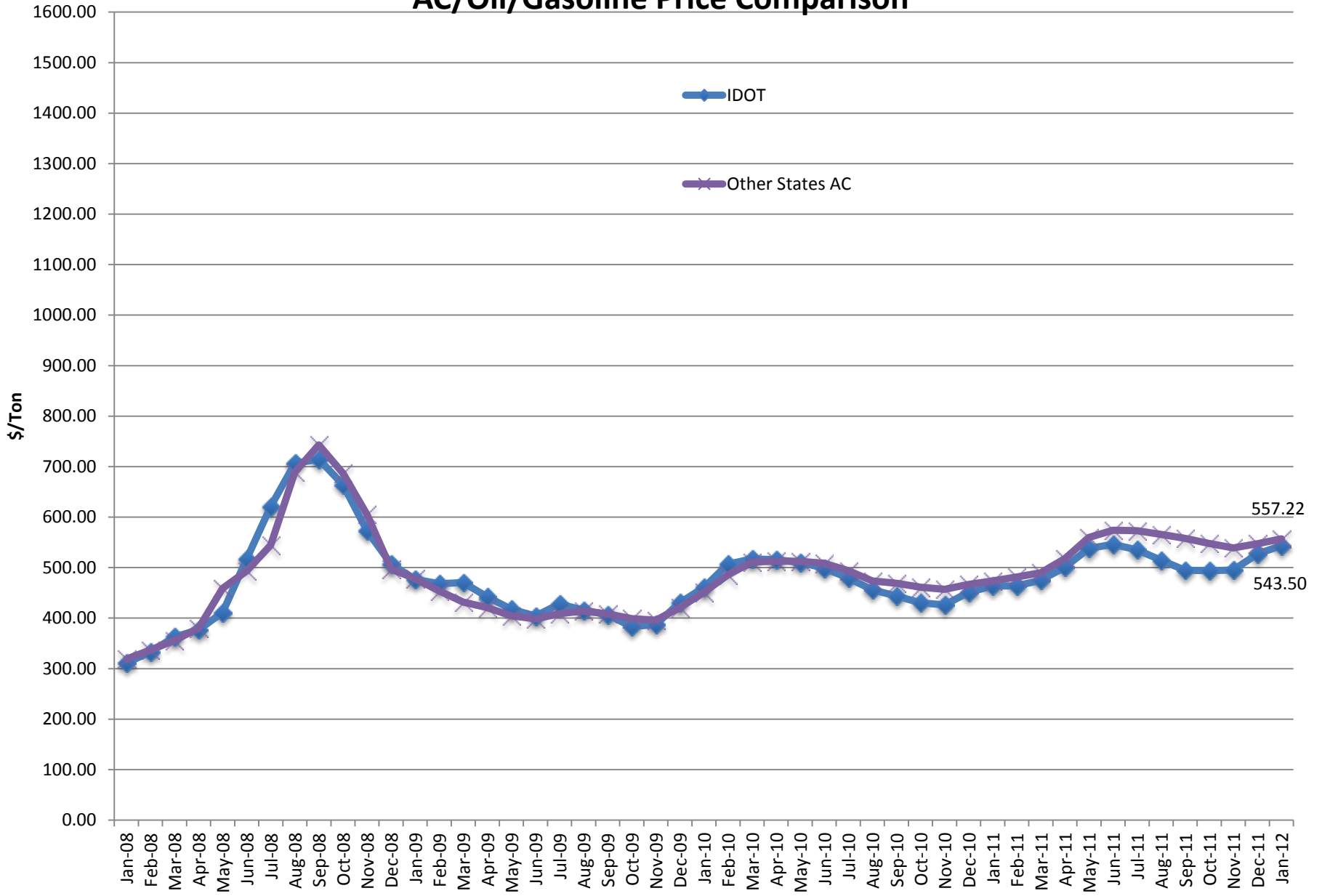

# Don't Get Rapped by RAP Aggregate







# RAP as Aggregate

**Know your spec – What is max top size??**

**3" 1 1/2" Other???**

**If providing unscreened/uncrushed RAP over 3"  
and IDOT pays for work as bid.**

**What have you done?**

**Did not follow spec.**

**Fraud?**



# Liquid AC Sampling at HMA Plants



# Sampling Points – Let's Count the Ways

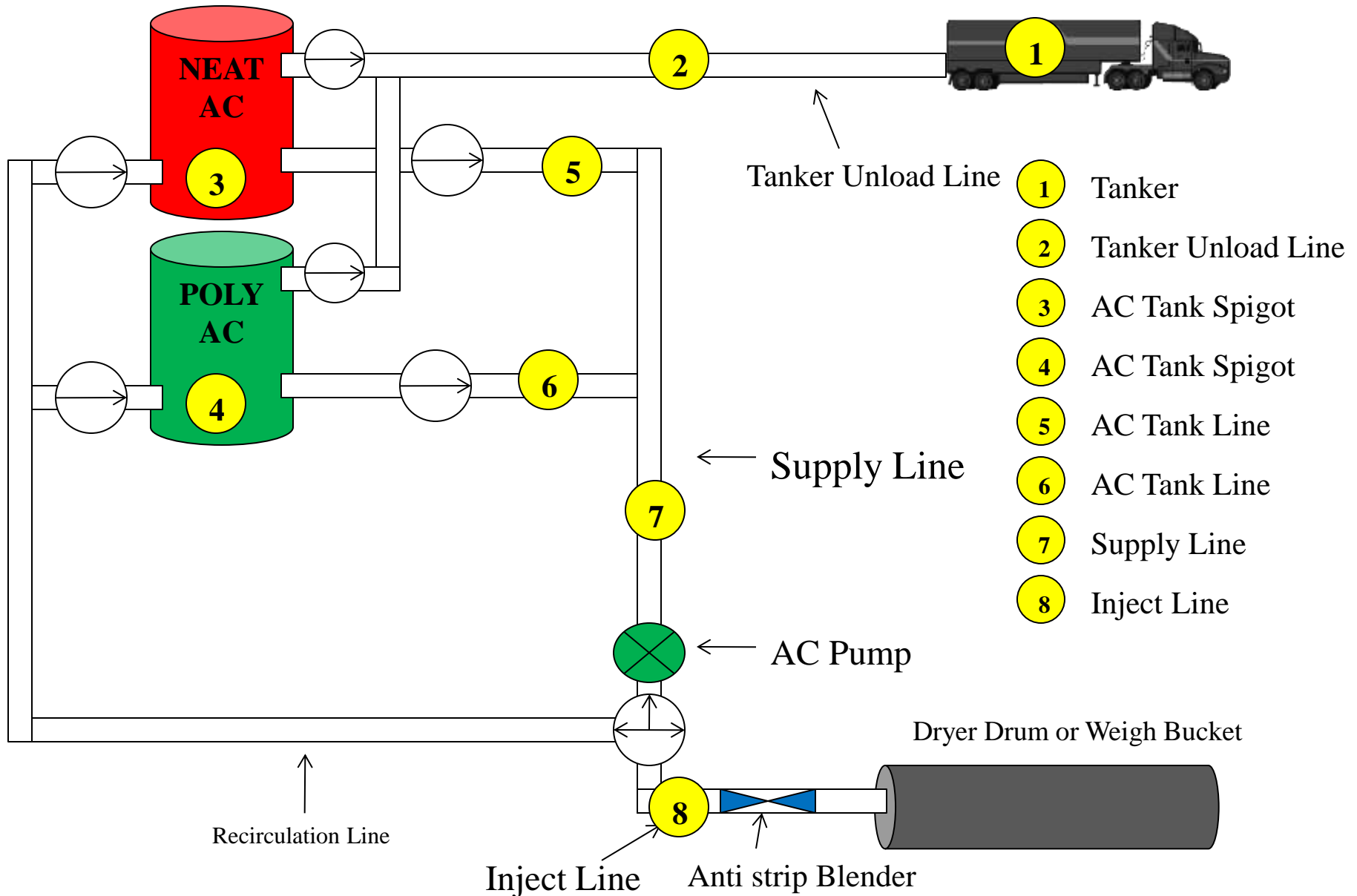



# Sample at closest point to the mix - at Injection Line

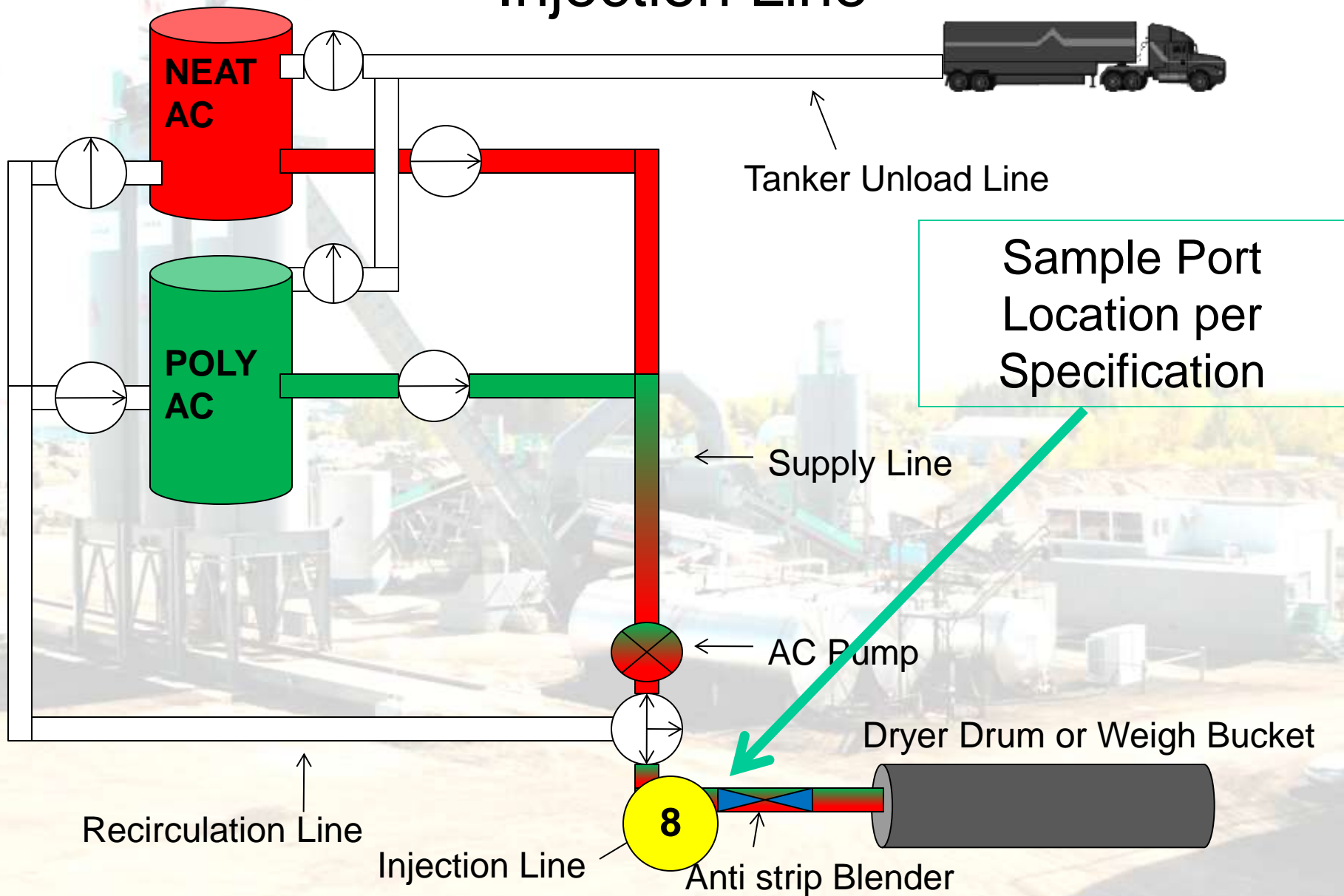

# District PG INV Field Samples

As of 12/31/11

District	Sample Total	Off Test	% Off Test 2011
1	357	11	3.2
2	122	3	2.5
3	57	0	0
4	112	0	0
5	95	0	0
6	189	2	1.1
7	179	0	0
8	260	0	0
9	99	1	1.0
<b>TOTAL</b>	<b>1425</b>	<b>17</b>	<b>1.2 %</b>

# District PG INV Field Samples

As of 12/31/11

District	Sample Total	Off Test	% Off Test 2011	% Off Test 2010
1	357	11	3.2	1.8
2	122	3	2.5	1.9
3	57	0	0	0.8
4	112	0	0	0
5	95	0	0	0
6	189	2	1.1	0.9
7	179	0	0	0.5
8	260	0	0	2.9
9	99	1	1.0	2.9
<b>TOTAL</b>	<b>1425</b>	<b>17</b>	<b>1.2 %</b>	<b>1.6 %</b>



# Warm Mix Asphalt

Hot

Warm

# WARM MIX ASPHALT (WMA)

- Jan 1, 2012 – BDE permissive use Spec issued
  - Allows WMA to be used by contractor
  - Limited to N70 and below mixes
  - Additives and Mechanical processes (foaming) allowed
  - Developing approved list of additives and processes

# Warm Mix Technology Use Procedure

- Contractor makes request for use to District
- District Coordinates with BMPR
- WMA Technology “Provisional” until TWO contracts completed within state.
- Evaluate on minimum of 2,000 tons of MAINLINE SURFACE MIX.
  - 1,000 tons of HMA control section
  - 1,000 tons of WMA Technology test section
- Mix testing
  - Four (4) gyros (HMA and WMA Technology).

# Warm Mix Technology Use Procedure

- Notify BMPR before production.
- Samples taken.
- Must meet Hamburg Wheel Tracking Device test requirements.
- Once two projects completed with success WMA technology has “approved” status.

Illinois Department of Transportation  
 Bureau of Materials and Physical Research  
**APPROVED / PROVISIONAL LIST OF  
 TECHNOLOGIES FOR PRODUCTION OF WARM MIX ASPHALT (WMA)**  
 December 16, 2011

BDE Permissive Use Specification for Warm Mix Asphalt (effective 1/1/2012)

**APPROVED TECHNOLOGIES LIST FOR WMA TECHNOLOGIES**  
 December 16, 2011

Company	WMA Technology		Date Approved
	Mechanical	Additive	

**PROVISIONAL TECHNOLOGIES LIST FOR WMA TECHNOLOGIES**  
 December 16, 2011

Company	WMA Technology		Date Provisionally Accepted
	Mechanical	Additive	
Astec Industries, Inc. 1725 Shepherd Road Chatanooga, TN 37421	Generation One (G1) of the Astec® Double Barrel Green System		12/2011
GENCOR INDUSTRIES, INC. 5201 North Orange Blossom Trail Orlando, Florida 32810	Gencor Ultrafoam GX™		12/2011
MAXAM Equipment, Inc. 1575 Universal Avenue Kansas City, MO 64120	MAXAM AQUABlack®		12/2011
Stansteel 12711 Townepark Way Louisville, KY, 40243	Stansteel Accu•Shear™		12/2011
Stansteel 12711 Townepark Way Louisville, KY, 40243	Stansteel Eco•Blend™		12/2011
Terex Corporation 200 Nyala Farm Road Westport, CT 06880 USA	Terex® Warm Mix Asphalt System		12/2011
MeadWestvaco 501 South 5th Street Richmond, VA 23219-0501		EVOTHERM™	12/2011
Sasol Wax North America Corporation 21325B Cabot Blvd Hayward, California 94545		SASOBIT®	12/2011
Akzo Nobel Surfactants 525 West Van Buren Street, Chicago, Illinois 60607-3823		REDISET™	12/2011





# Reclaimed Asphalt Shingle (RAS) Update

# Shingle Legislation

- **HB 1326 signed into law by Gov. Quinn**
  - **Now Public Act 097-0314**
  - **Effective 1/1/12**
- **CDD sites: Credit of 2 tons for every ton of shingles recycled to reach 75% goal**
- **Requires IDOT to maximize the use of shingles for binder replacement in HMA mixes on State highways**

# Other Provisions of PA 97-0314

- Maximize the use of recycled materials
- Reduce the carbon footprint
- Reduce average cost
- Report annually to the Legislature all Department efforts initiated or abandoned in each District/Region

# RAS Usage Status

- BDE Special Provision for Reclaimed Asphalt Shingles (RAS) Effective 1/1/12
  - Allows RAS to be used statewide
  - Works with BDE Special Provision for Reclaimed Asphalt Pavement (RAP)
- Expecting to see a number of mix designs adopting shingles in 2012 – Especially D-1, 2, 3 and 4
- Includes Hamburg requirement

Asphalt Binder Grade	# Repetitions	Maximum Rut Depth in. (mm)
PG76-XX	20,000	1/2 (12.5)
PG70-XX	15,000	1/2 (12.5)
PG64-XX	10,000	1/2 (12.5)
PG58-XX	10,000	1/2 (12.5)

# RAS Specs and Policy

- Two Specs that work together
  - RAS: <http://www.dot.il.gov/desenv/pdf/80282.pdf>
  - RAP: <http://www.dot.il.gov/desenv/pdf/80172.pdf>
  - Will combine into single spec for 2013
- Policy revised issued August 2011
  - Link: <http://www.dot.il.gov/materials/pdf/28-10.2reclaimedasphaltshinglesources.pdf>

# RAS Sources

Owner	Location	Type
Falcon Green Resources, Inc P.O. Box 638 Harvard, IL 60033	1200 N Rose Farm Rd Woodstock, IL 60098	Type 1
Southwind RAS, LLC 2250 Southwind Boulevard Bartlett, IL 60103	1950 Vulcan Blvd Bartlett, IL 60103	Type 2
Southwind RAS, LLC 2250 Southwind Boulevard Bartlett, IL 60103	6616 Darst Street Peoria, IL 60103	Type 2
Southwind RAS, LLC 2250 Southwind Boulevard Bartlett, IL 60103	4401 S. First Avenue Lyons, IL 60534	Type 2

Link: <http://www.dot.il.gov/materials/reclaimedasphaltshingles.pdf>

# Hamburg Wheel



# Specimen Prep

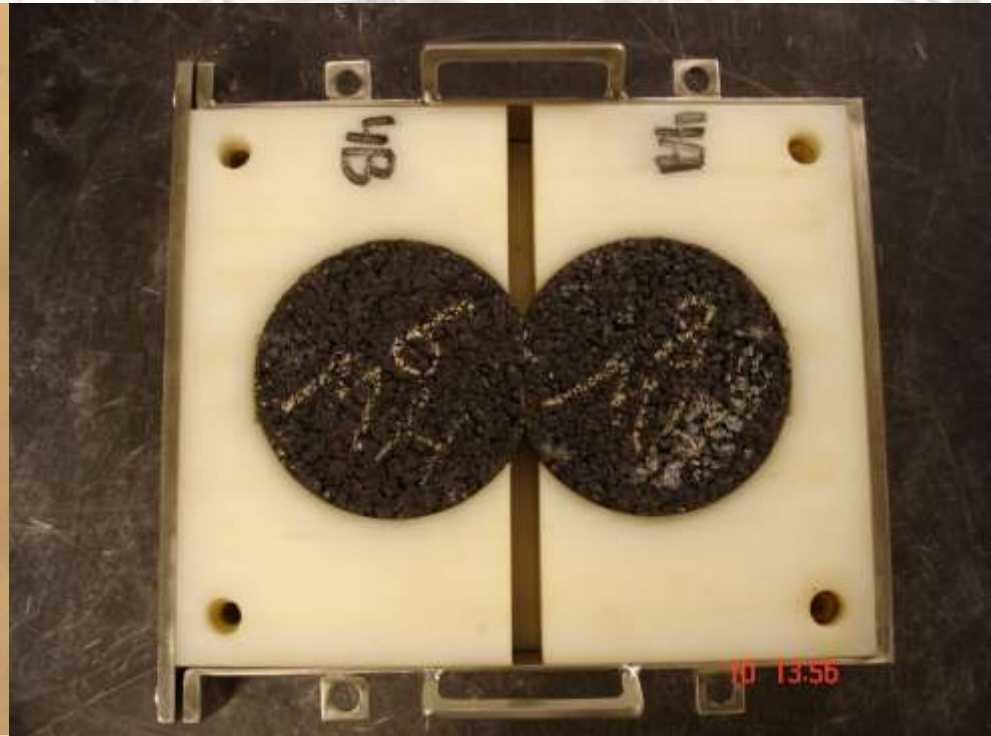



# Hamburg Wheel

50 Passes/Minute

158 Lbs

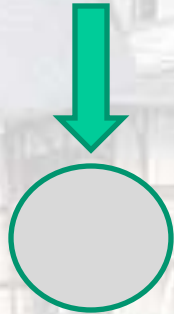

50 C

AASHTO T-324



**Fail**



**Pass**

# Implementation Schedule

The background of the slide features a faded, historical-style photograph. It depicts a grand, multi-story building with a prominent clock tower and several smaller spires. The architecture is reminiscent of a 19th-century town hall or a large public building. In the foreground, several horse-drawn carriages are visible, some with drivers and passengers, suggesting a scene from a past era. The overall tone is sepia or light brown, giving it a historical feel.

- 2011
  - High Replacement RAP and RAS
  - Warm Mix
- 2012 - 2013
  - Other New mixes (fine graded) and Renewals
- 2014 on
  - Full Implementation

# Results

- Most mixes pass
- For those that don't..
  - Review anti-strip usage
    - Liquid
    - Lime
  - Add shingles – fibers and harder AC help
  - Add RAP
  - Change WMA technology

# Life Cycle Cost Audit



# Audit

- 20 ILCS 2705/2705-590
  - Requires Life Cycle Costing (LCC) on all projects over \$500,000
  - Award construction to lowest LCC
  - Models based upon data
  - If don't have data may use other similar states data
- Audit to determine if IDOT following law
- Not concluded yet

# Pavement Design Update



# Pavement Design Update

April 2011

- Thickness Design
  - HMA
  - PCC (Jointed)
- Maintenance Models
  - HMA + Rubblizing
  - PCC (Jointed, CRC and Unbonded PCC Overlay)
- Alternate bids for projects within 10%



# Common to Both Designs

- Additional Subgrade treatment
  - Added aggregate/lime combo
- Reduced Non-Interstate Minimum Design Traffic
- Complete Recheck of Design Theory
  - Compared to AASHTO – MEPDG
  - Outside Reviewers for Both Designs and Selection Process as a QA Check

# Pavement Thickness

- PCC Thickness
  - Little change
- HMA Thickness
  - Revised fatigue algorithm
  - Updated pavement temperature data
  - PG asphalt grade
  - Included limiting strain criteria
    - Low strain = unlimited life

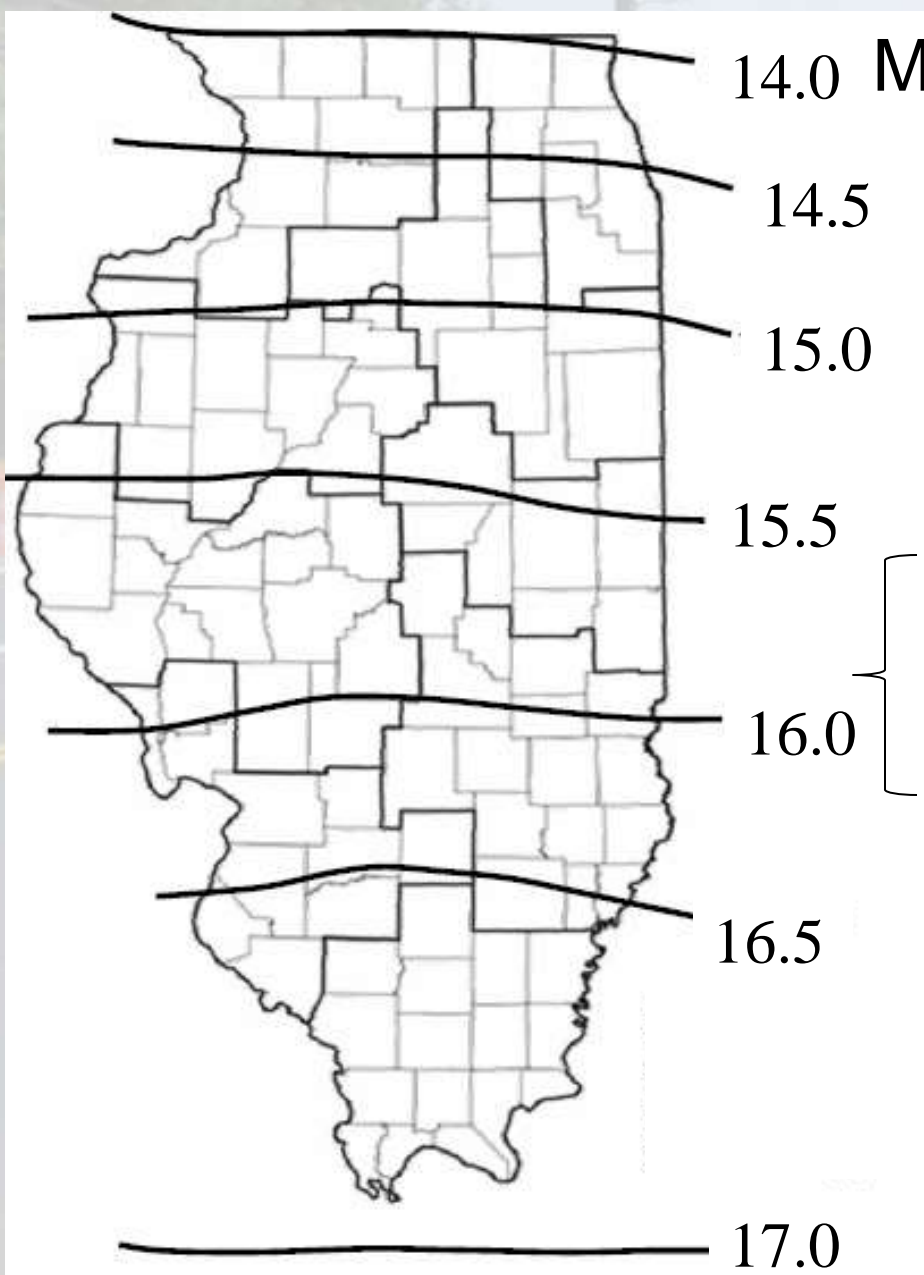

# 14.0 Maximum Pavement Thickness

14.5

15.0

15.5

16.0

16.5

17.0

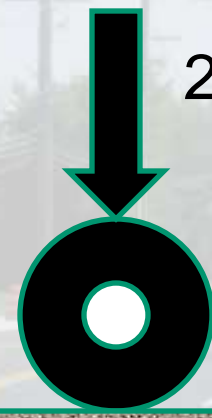

20K

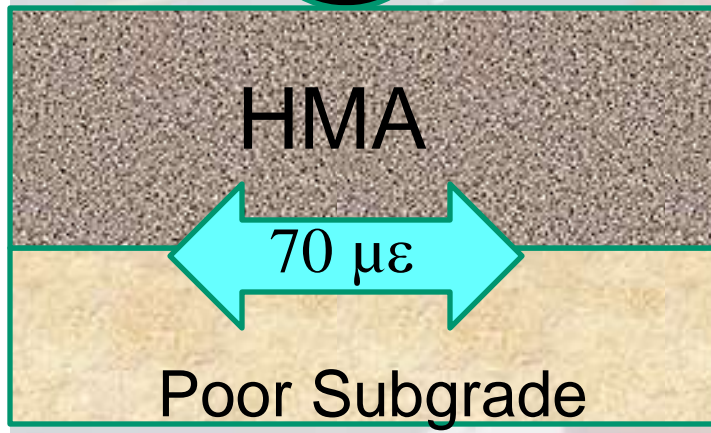



**PAY FOR  
PERFORMANCE**

# PFP Implementation Schedule

## ✓ 2010

- ✓ Min. One PFP project / District
  - ✓  $\geq 8,000$  tons individual mix

## ✓ 2011

- ✓ Min. 50% of all Interstate or Supplemental Expressway
  - ✓  $\geq 8,000$  tons / mix

## • 2012

- All Interstate & Supplemental Expressway
  - $\geq 8,000$  tons / mix

# 2011 PFP Projects

District	Projects	Tons	% Jobsite Sampling
1	3 (4 w/ carryover)	29,011 (42,988)	0
2	(3 carryover)	(67,463)	100
3	N/A	N/A	N/A
4	2	20,000	100
5	2	31,300	100
6	(2)	36123	100
7	1	9,737	100
8	2	177,000	100
9	(1 carryover)	(12,946)	0
Total	10 (17)	267,048 (397,557)	

# 2011 PFP Projects

Final Pay								
1	2	3	4	5	6	7	8	9
97.4%	101.2%	N/A	99.7%	<b>93.4%</b>	101.1%	100.6%	94.0%	97.1%
100.6%	102.6%		102.1%	101.5%	99.6%		95.8%	
98.5%	100.6%							
94.5%								
100.8%								
<b>102.8%</b>								
98.6%								
99.8%								
96.2%								
99.5%								
99.1%								
98.8%								
98.2%							Average=	99.0%

# Spec Revisions for 2012

- Increase core/edge distance to 4-inches
- Disputes within precision limits will no longer be allowed
- Dispute cores taken with District cores
- Better filling of core holes
- Lab fees increased
  - Mix      \$1,000
  - Core     \$300





**Q**UALITY

**C**ONTROL FOR

**P**ERFORMANCE

# QCP - Quality Control for Performance

- For use below PFP (8,000 tons) & other projects not suited for PFP
- Uses pay adjustment concept
- Pay based upon owner test
- Less effort for owner than PFP
- Roll out
  - 2012 - 2 state projects/district
  - 2013 - 50%
  - 2014 - Full implementation on state
  - 2014 - Start LR&S

# N – Design Mix Reduction

# HMA N Design

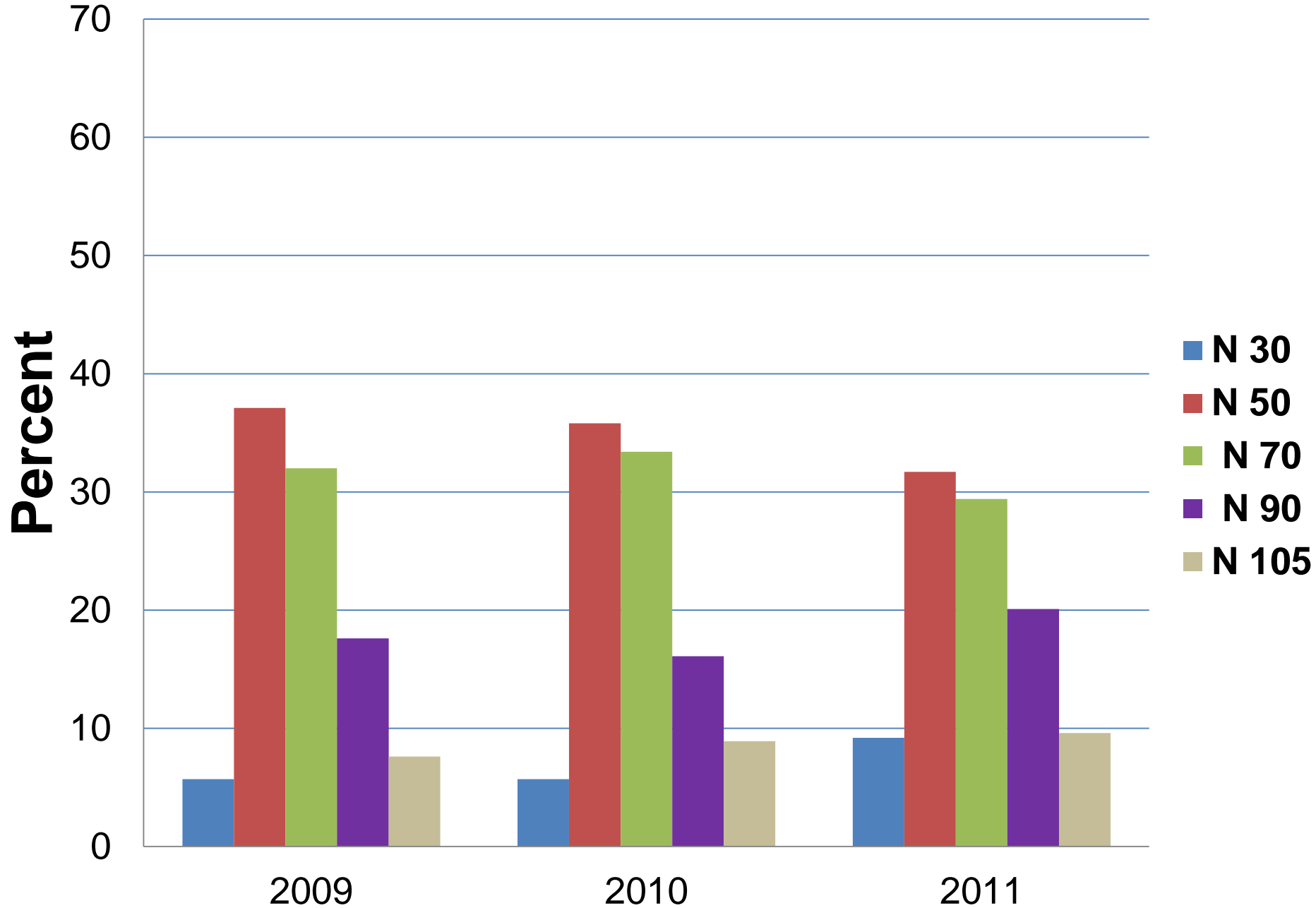

# Proposed 3 Levels

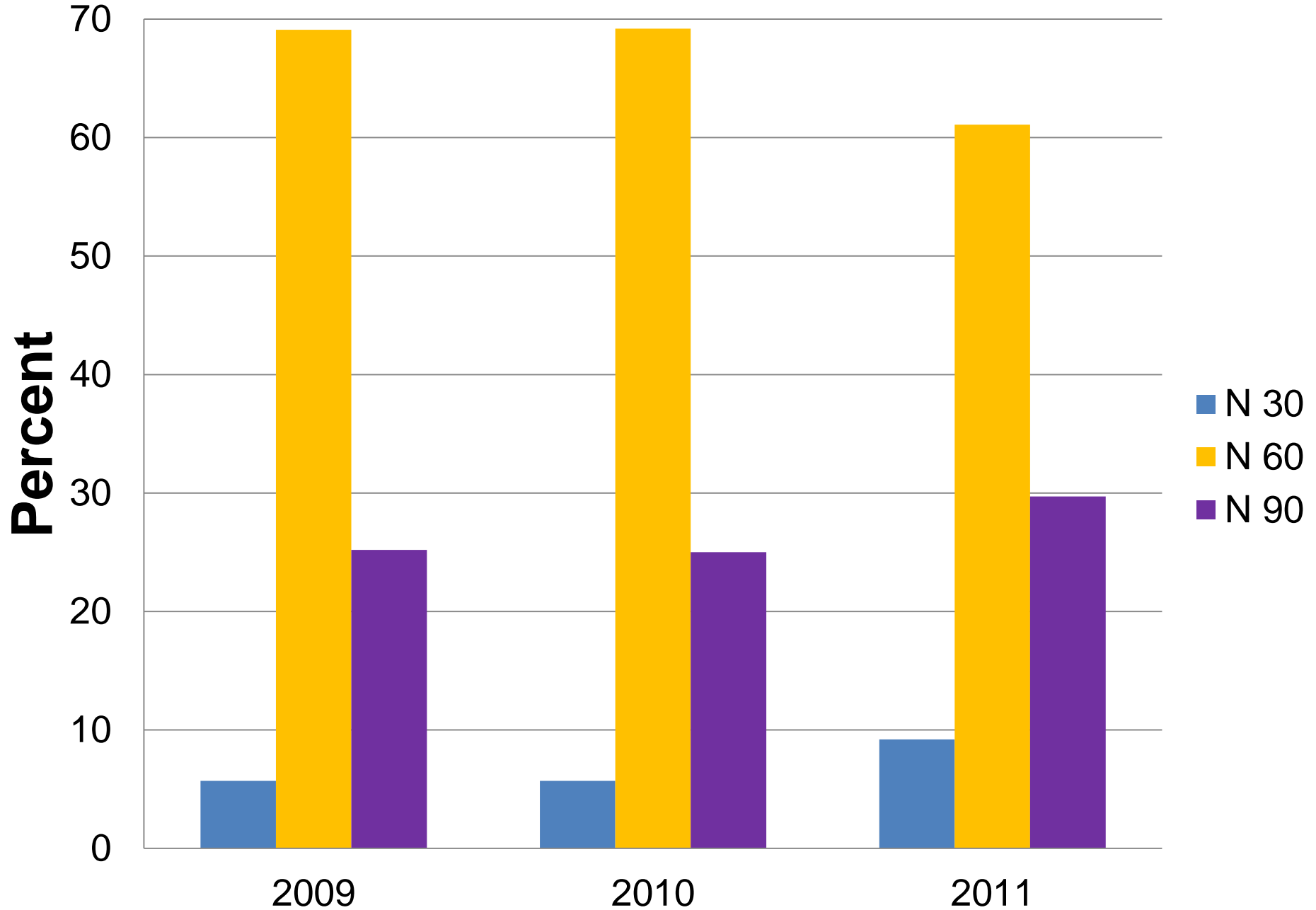

# Proposed 4 Levels

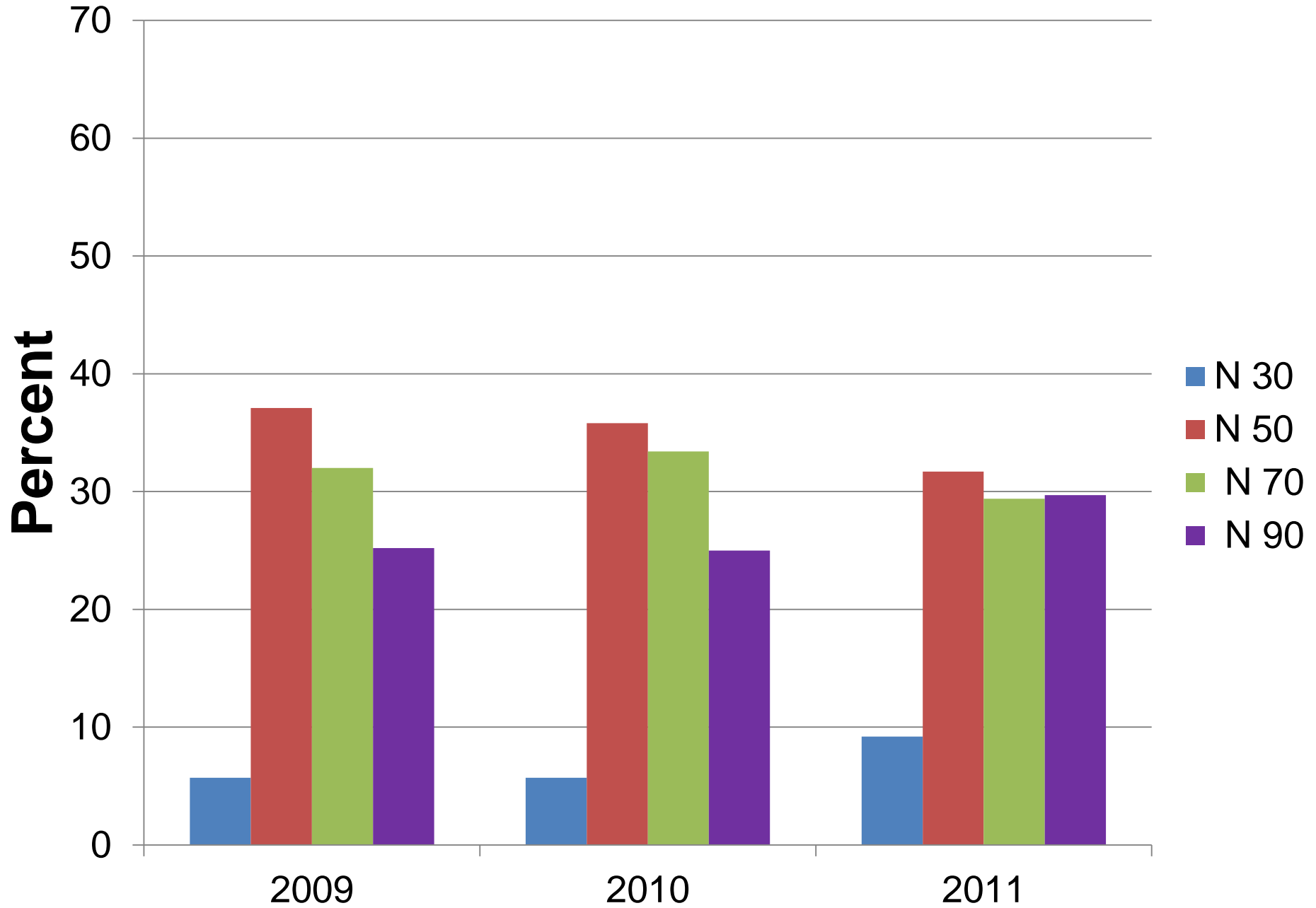

# NCHRP Report 573 by NCAT

- ◎ Gyration Levels for  $N_{\text{design}}$
- ◎ For mixes under PG 76-xx
  - Four levels
  - 50, 65, 80, 100
- ◎ Possible IDOT mixes
  - 30, 50, 70, 90 – may not be far off





