



CIVIL ENGINEERING STUDIES  
Illinois Center for Transportation Series No. 12-018  
UIIU-ENG-2012-2020  
ISSN: 0197-9191

# **LABORATORY EVALUATION OF HIGH ASPHALT BINDER REPLACEMENT WITH RECYCLED ASPHALT SHINGLES (RAS) FOR A LOW N-DESIGN ASPHALT MIXTURE**

Prepared By

**Hasan Ozer  
Imad L. Al-Qadi  
Ahmad Kanaan**

Research Report FHWA-ICT-12-018

A report of the findings of R27-SP19  
**Laboratory Evaluation of High Asphalt Binder Replacement with Recycled  
Asphalt Shingles (RAS) for a Low N-Design Asphalt Mixture**

Illinois Center for Transportation

October 2012

Technical Report Documentation Page

1. Report No. FHWA-ICT-12-018		2. Government Accession No.		3. Recipient's Catalog No.	
4. Title and Subtitle Laboratory Evaluation of High Asphalt Binder Replacement with Recycled Asphalt Shingles (RAS) for a Low N-Design Asphalt Mixture				5. Report Date October 2012	
				6. Performing Organization Code	
7. Author(s) Hasan Ozer, Imad L. Al-Qadi, and Ahmad Kanaan				8. Performing Organization Report No. ICT-12-018 UILU-ENG-2012-2020	
9. Performing Organization Name and Address  Illinois Center for Transportation Department of Civil and Environmental Engineering University of Illinois at Urbana-Champaign 1611 Titan Drive, Rantoul, IL, 61866				10. Work Unit (TRAIS)	
				11. Contract or Grant No. R27-SP19	
				13. Type of Report and Period Covered	
12. Sponsoring Agency Name and Address Illinois Department of Transportation Bureau of Materials and Physical Research 126 East Ash Street, Springfield, IL 62704-9766				14. Sponsoring Agency Code	
15. Supplementary Notes					
16. Abstract  This study investigated the effect of high asphalt binder replacement for a low N-design asphalt mixture including RAP and RAS on performance indicators such as permanent deformation, fracture, fatigue potentials, and stiffness, was studied. An experimental program included complex modulus, fracture, overlay reflective cracking resistance, wheel track permanent deformations, and push-pull fatigue tests. The asphalt binder replacement, combinations of RAS and RAP asphalt binder, levels in the mix were in a range of 43 to 64%. According to the results obtained from the experimental program, permanent deformation resistance of the mixtures was improved in the presence of RAS. Fracture tests at low temperature did not reveal any significant difference between the specimens prepared at varying percentages of asphalt binder replacement. Fatigue potential of mixtures increased with increasing RAS content and asphalt binder replacement. The specimens prepared with 2.5% RAS and PG 46-34 showed the best fatigue performance. The impact of asphalt binder bumping was highlighted by the results of all tests. The improvement in fatigue life and fracture energy was noticeable when the asphalt binder type was changed from PG 58-28 to PG 46-34 at the highest asphalt binder replacement level. The results showed that complex modulus test results can provide crucial information about the mix viscoelastic properties such as relaxation potential and long-term stiffness that can be used, along with fracture tests, to evaluate mix brittleness at relatively high asphalt binder replacement levels.					
17. Key Words Recycled materials, asphalt binder replacement, RAP, RAS			18. Distribution Statement No restrictions. This document is available to the public through the National Technical Information Service, Springfield, Virginia 22161.		
19. Security Classification (of this report) Unclassified.		20. Security Classification (of this page) Unclassified.		21. No of Pages 32 pp. plus appendices	22. Price

## **ACKNOWLEDGMENT**

This report is based on the results of the project ICT-R27-SP19, Laboratory Evaluation of High Asphalt Binder Replacement with Recycled Asphalt Shingles (RAS) for a Low N-Design Asphalt Mixture. ICT R27-SP19 was conducted in cooperation with the Illinois Center for Transportation; U.S. Department of Transportation; and Federal Highway Administration.

The input by the project technical advisory panel is greatly appreciated. The authors would also like to acknowledge the contribution of the Texas Department of Transportation for the overlay tests conducted in their facilities.

## **DISCLAIMER**

The contents of this report reflect the view of the authors, who are responsible for the facts and the accuracy of the data presented herein. The contents do not necessarily reflect the official views or policies of the Illinois Center for Transportation, the Illinois Department of Transportation, or the Federal Highway Administration. This report does not constitute a standard, specification, or regulation.

## EXECUTIVE SUMMARY

The influence of high asphalt binder replacement for a low N-design asphalt mixture on some of the performance indicators such as permanent deformation resistance, fracture potential, fatigue performance, and stiffness, were studied utilizing a comprehensive experimental program. The experimental program included complex modulus, fracture, overlay reflective cracking resistance, wheel track permanent deformations, and push-pull fatigue tests. In the laboratory tests, specimens were compacted from plant-produced mixes for the entire experimental program and fabricated from field cores for fracture and wheel track tests. The experimental program was designed to highlight potential strength and weaknesses of an asphalt mixture at high asphalt binder replacement levels.

The mixtures investigated in this study included reclaimed asphalt pavement (RAP) and recycled asphalt shingles (RAS) to achieve asphalt binder replacement values at a range of 43% to 64%. Three mixtures at varying asphalt binder replacement levels were designed by using 2.5%, 5.0%, and 7.5% RAS. In addition, the mixture at the highest asphalt binder replacement level (64% replacement with 7.5% RAS) was also produced using PG 46-34 and PG 58-28 to evaluate the impact of grade bumping. The rest of the mixes were produced using asphalt binder grade PG 46-34.

According to the results from the experimental program, permanent deformation resistance of the mixtures was improved in the presence of RAS. Fracture tests at low temperature did not reveal any significant differences between the specimens prepared at varying percentages of asphalt binder replacement. However, fatigue performance of mixtures with both the push-pull fatigue test and the Texas Transportation Institute (TTI) Overlay Tester, results deteriorated with increasing RAS content and asphalt binder replacement. The specimens prepared with 2.5% RAS and PG 46-34 showed the best performance in both of the fatigue tests. The impact of asphalt binder bumping was highlighted by the results of all tests. The mixes with PG 58-28 had the lowest fracture energy (indicating higher cracking potential), the lowest number of cycles to failure consistently with the two types of fatigue tests, and distinctive complex modulus results. The improvement in fatigue performance and fracture energy was noticeable when the asphalt binder type was changed from PG 58-28 to PG 46-34 at the highest asphalt binder replacement level. The results also showed that complex modulus test results can provide crucial information about viscoelastic properties of mixes such as relaxation potential and long-term stiffness that can be used along with fracture tests to evaluate brittle mixes at high asphalt binder replacement levels.

# TABLE OF CONTENTS

<b>CHAPTER 1 INTRODUCTION</b> .....	1
<b>1.1 Background</b> .....	1
<b>1.2 Objective</b> .....	2
<b>1.3 Research Approach</b> .....	2
<b>CHAPTER 2 TESTING PROCEDURES AND MATERIALS</b> .....	3
<b>2.1 Materials</b> .....	3
<b>2.2 Sample Preparation</b> .....	4
<b>2.3 Test Procedures</b> .....	4
2.3.1 Complex Modulus Testing.....	5
2.3.2 Hamburg Wheel Track Testing.....	6
2.3.3 Fracture Testing.....	9
2.3.4 Fatigue Testing .....	13
<b>CHAPTER 3 RESULTS AND ANALYSIS</b> .....	16
<b>3.1 Complex Modulus Test Results</b> .....	16
<b>3.2 Hamburg Wheel Track Test Results</b> .....	18
<b>3.3 Fracture Testing Results</b> .....	20
<b>3.4 Fatigue Testing Results</b> .....	23
3.4.1 TTI Overlay Test Results.....	23
3.4.2 Push-Pull Test Results .....	23
<b>CHAPTER 4 SUMMARY AND CONCLUSIONS</b> .....	29
<b>REFERENCES</b> .....	31
<b>APPENDIX A PHOTOS OF WHEEL TRACK TEST SAMPLES AFTER TESTING</b> .....	A-1
<b>APPENDIX B MIXTURE DESIGN AND MATERIALS GRADATION</b> .....	B-1

# CHAPTER 1 INTRODUCTION

## 1.1 BACKGROUND

The increasing demand for asphalt products requires the asphalt industry to move toward reducing cost and protecting the environment. A common practice, begun in the mid-1970s in the United States, is the use of recycled materials in hot mix asphalt (HMA) such as reclaimed asphalt pavement (RAP), and more recently recycled asphalt shingles (RAS), while this may have been done since 30-40 years ago, the economics of it were not viable until recently. I would say most RAS programs are 6-10 years old or less. The use of RAP became widely accepted in the United States as a replacement for virgin asphalt binder and virgin aggregates in the mixture in order to reduce the cost and the environment impact. In recent years, RAS also started to become a widely used alternative product in mixtures. In the year of 2010, the Illinois Department of Transportation (IDOT) used about 1.7 million tons of recycled materials in highway construction projects in the State of Illinois (Brownlee 2011). While using recycled products results in reduced mixture costs and helps achieve more sustainable pavements, it is critically important to ensure performance of pavements built with mixtures containing recycled products. This study focuses on some of the performance measures of asphalt mixtures with containing RAS and RAP. A brief discussion on the background of using RAS in asphalt mixtures and its influence on performance characteristics is provided in this report.

Several research studies have been conducted throughout the United States to evaluate the effect of using RAS in asphalt mixtures. One of the reasons that RAS became of an interest for many research studies is that RAS contains a high percentage of asphalt binder (18%–30%), which can replace a high percentage of the HMA virgin asphalt binder and thereby help reduce the cost. In addition, RAS is widely available in the United States and comes from two main sources. Shingles that are rejected by the manufacturer are called manufacturer waste scrap shingles (MWSS); this source provides a small amount of shingles for recycling and use in asphalt mixtures. Shingles removed during re-roofing, called tear-off scrap shingles (TOSS), are a more plentiful source (Goh and You 2011). Approximately, eleven million tons of roof shingles are disposed of in landfills every year throughout the United States (Goh and You 2011).

The effect of RAS on the performance of asphalt mixtures can be evaluated with two distinct criteria: low-temperature cracking and permanent deformation. The greatest concern that limits use of RAP and RAS in HMA is the effect of RAP or RAS aged asphalt binder that may be partially or fully replacing the HMA virgin asphalt binder. The effect of aged asphalt binder is of great concern as the aged asphalt binder becomes stiffer with the effect of aging, especially at lower temperatures, which impacts or degrades the mixture's resistance to thermal cracking. On the other hand, the use of RAS in asphalt mixtures was shown to improve the mixture's resistance to rutting or permanent deformations at intermediate and higher pavement temperatures (Goh and You 2011; Mogawer et al. 2011; Ma, Mahmoud, and Bahia 2010).

The effect on performance properties of asphalt mixtures with RAS only and with both RAP and RAS has been investigated by many researchers. In one of the earlier attempts, it was found that mixture stiffness increased with an increase in MWSS content up to 5%, but mixture stiffness adversely decreased beyond 5% (Newcomb et al. 1993). In the same study, the presence of TOSS resulted in stiffening of the mixture. The indirect tensile (IDT) test run at low temperature showed a decrease in low-temperature resistance with increasing shingle content. Button et al. (1996) arrived at the same conclusion when using

5% RAS in HMA. They also recommended increasing the mixing/compaction temperatures by 10°C (50°F) to 20°C (68°F). On the other hand, several research studies show that resulting mix properties with the addition of RAS depend on the grinding size when the RAS is used in the mix.

McGraw et al. (2007) investigated the use of TOSS and MWSS combined with traditional RAP materials. They observed that addition of RAS lowered the temperature susceptibility of the asphalt binders. The results indicated that the two types of shingles performed differently. MWSS and TOSS both increased the stiffness of the mixtures. However, the presence of MWSS did not show significant influence on the strength of mixtures and extracted asphalt binders, while TOSS lowered the strength of the asphalt binder significantly at the higher test temperature and increased the asphalt binder's critical temperature.

## **1.2 OBJECTIVE**

The objective of this study is to evaluate the effect of RAS on mechanical properties of an asphalt mixture at high asphalt binder replacement levels. High asphalt binder replacement can be achieved using RAP and RAS together in a mix. The effect of high asphalt binder replacement with the existence of varying levels of RAS on fracture, fatigue, modulus, and permanent deformation characteristics constitutes the main objective of this study.

## **1.3 RESEARCH APPROACH**

In this study, an experimental program was performed on an asphalt mixture with varying percentages of RAS. Loose plant samples and field cores were provided by the Illinois Department of Transportation (IDOT) to be evaluated for strength, permanent deformation, and dynamic modulus, and to determine the fracture properties of mixtures that contain various percentages of RAS. Two asphalt binder grades were used in these mixtures, PG 46-34 and PG 58-28. The mixtures with PG 46-34 were evaluated with 2.5%, 5.0%, and 7.5% RAS, while the mixes with PG 58-28 were evaluated with 7.5% RAS only. These mixes also contained fractionated recycled asphalt pavement (FRAP) along with RAS. Total asphalt binder replacement varied from 43% to 64% for different levels of RAS.

## CHAPTER 2 TESTING PROCEDURES AND MATERIALS

### 2.1 MATERIALS

Loose plant samples and field cores of two asphalt binder grades and different percentages of RAS were used in this study. The mixture is a N30 at 2.0% design air voids. PG 58-28 asphalt binder was used with 7.5% RAS and 37.5% FRAP, and PG 46-34 asphalt binder was used with 2.5%, 5.0%, and 7.5% RAS with different percentages of FRAP. The details of the mix designs for the mixes produced in the plant are provided in Appendix B.

The source of RAS used in this study was TOSS with approximately 25% residual asphalt binder content, 40.0% sand, and 7%–10% cellulose fibers by weight of RAS. The total asphalt binder content of these mixes was approximately 6.3% AC, while the amount of the virgin asphalt binder was only 2.2%. Total asphalt binder replacement value with RAS and RAP asphalt binder was about 64% of the total asphalt binder content. Table 1 shows the RAP gradation and the RAS washed gradation after extraction. The gradation data from dry shake analysis for RAS was not available to the researchers.

Table 1. RAP and RAS Gradation Determined After Washed Gradation

Sieve Size	IDOT RAS Specifications <sup>1</sup>	% Passing (RAS)	% Passing (Coarse RAP)	% Passing (Fine RAP)
1"(25.0mm)		100.0	100.0	100.0
3/4"(19.0mm)		100.0	100.0	100.0
1/2"(12.5mm)		100.0	100.0	100.0
3/8"(9.5mm)	100.0	98.6	100.0	100.0
No.4 (4.75mm)	93.0	94.0	59.0	92.2
No.8 (2.36mm)		90.0	38.4	95.5
No.16 (1.18mm)		73.0	28.8	48.5
No.30 (600µm)		53.0	22.8	36.4
No.50 (300µm)		43.0	15.6	23.7
No.100 (150µm)		36.0	9.6	14.3
No.200 (75µm)		28.0	6.8	10.2
AC (%)		26.0	4.7	6.4

<sup>1</sup> Based on dry shake.

According to the mix design followed for each mix, different asphalt binder replacement levels were obtained. RAS content was changed from 2.5% to 7.5% in the asphalt mix, while total asphalt binder content was fixed. Table 2 shows the percentages of RAP and RAS in each mix and the corresponding asphalt binder replacement level. As shown in the table, the asphalt binder replacement level for the mix with 7.5% RAS can be as high as 64%.



Table 2. Asphalt Binder Replacement Levels for Each Mix Used in the Study

	<b>Coarse RAP (% by weight in mix)</b>	<b>Fine RAP (% by weight in mix)</b>	<b>RAS (% by weight in mix)</b>	<b>Asphalt Binder Replacement<sup>1</sup> (%)</b>
2.5% RAS	20.0	17.5	7.5	43
5.0% RAS	20.0	15.0	5.0	51
7.5% RAS	20.0	12.5	2.5	64

$$^1 \text{ Asphalt Binder Replacement} = \frac{\text{Recycled Asphalt Binder (RAP and RAS)}}{\text{Total Asphalt Binder Content}} * 100$$

## 2.2 SAMPLE PREPARATION

The loose mixtures were provided by IDOT in buckets of about 20–30 kg (45-65 lb) each. Each bucket was split and reduced to the weight of the samples required for testing according to Illinois Modified AASHTO R47-08 standards for reducing samples of HMA. The Superpave Gyratory Compactor (GPC) was used to prepare cylindrical samples with a diameter of 150.0 mm (5.9 in) according to Illinois Modified AASHTO T312-09. The height of the compacted samples was selected depending on the test they were prepared for: a height of 130.0 mm (5.1 in) was used for the Wheel Track Test samples, while a height of 180.0 mm (7.0 in) was used to prepare samples for other tests. Samples were compacted at a compaction temperature of 146°C (295°F). A target percent of air voids was selected as 6.0 ± 1.0%. Target density for most of the specimens was achieved within three to five gyrations. It is important to note that the volumetrics of these mixes is not typical of conventional IDOT mixes. Field cores were also obtained and were processed to fabricate fracture and wheel track tests specimens.

## 2.3 TEST PROCEDURES

The following testing suite was followed to evaluate the effect of RAS on fracture, rutting, and fatigue performance of the mixes obtained in this study. A summary of the test matrix is also shown in Table 3.

- The Hamburg wheel track test (WTT) (Illinois Modified AASHTO T340) was used to evaluate the mixtures' resistance to rutting or permanent deformation.
- The semi-circular bending beam (SCB) and disc compact tension tests (ASTM D7313) were used to evaluate low-temperature cracking resistance of the mixtures.
- The complex modulus test (AASHTO TP62-03) was conducted to evaluate stiffness increase in mixes with RAP and RAS at different temperatures and loading speeds.
- The push-pull fatigue test was conducted to measure damage evolution in the mixes at intermediate temperatures.
- The Texas Transportation Institute (TTI) Overlay Test was used to evaluate the mixtures' resistance to reflective cracking at intermediate temperatures.

Table 3. Test Matrix Used to Evaluate the Effect of RAS on Fracture, Rutting, and Modulus Properties of an Asphalt Mixture

Sample source	Sample Identification	Test Procedure
Loose Plant	PG 58-28 and 7.5% RAS/ 37.5% FRAP	Hamburg, SCB, overlay test, dynamic modulus, and push-pull fatigue test
	PG 46-34 and 7.5% RAS/ 37.5% FRAP	Hamburg, SCB, DCT, overlay test, dynamic modulus, and Push-Pull Fatigue Test
	PG 46-34 and 5.0% RAS/ 35% FRAP	Hamburg, SCB, DCT, overlay test, dynamic modulus, and push-pull fatigue test
	PG 46-34 and 2.5% RAS/ 32.5% FRAP	Hamburg, SCB, overlay test, dynamic modulus, and push-pull fatigue test
Field Cores	PG 58-28 and PG46-34 and 7.5% RAS/37.5% FRAP	Hamburg and SCB
	PG 46-34 and 7.5% RAS/ 37.5% FRAP	Hamburg and SCB

### 2.3.1 Complex Modulus Testing

Complex modulus ( $E^*$ ) defines the relationship between stress and strain for a linear viscoelastic material under sinusoidal loading. Complex modulus is one of the material characterization inputs that can be used in the Mechanistic Empirical Pavement Design Guide (MEPDG) to model pavement performances. In this study the tests were performed for each mix in a temperature-controlled chamber at ( $-10^{\circ}\text{C}$  ( $14^{\circ}\text{F}$ ),  $4^{\circ}\text{C}$  ( $39^{\circ}\text{F}$ ),  $21^{\circ}\text{C}$  ( $70^{\circ}\text{F}$ ), and  $37^{\circ}\text{C}$  ( $99^{\circ}\text{F}$ )) and at loading frequencies of 25, 10, 5, 1, 0.5, and 0.1Hz according to the test protocol AASHTO TP62-03. The tests were conducted using a controlled stress mode with a specified strain limit of 50 microstrains in order to ensure that the material was within the linear viscoelastic limit. Test samples were prepared and cut from the 180.0 mm (7.0 in) laboratory-compacted specimens to a standard sample size of 150.0 mm (5.9 in) height and a diameter of 101.6 mm (4.0 in), in accordance with AASHTO TP62-03 standards. At least two replicates were used for each type of mixture in this study. Figure 1 shows the ( $E^*$ ) machine setup, while Figure 2 illustrates the number of replicates used with each mix and the distribution of air voids for each replicate, as well as the number of gyrations required to achieve target density.



Figure 1. Dynamic modulus testing fixture and setup.

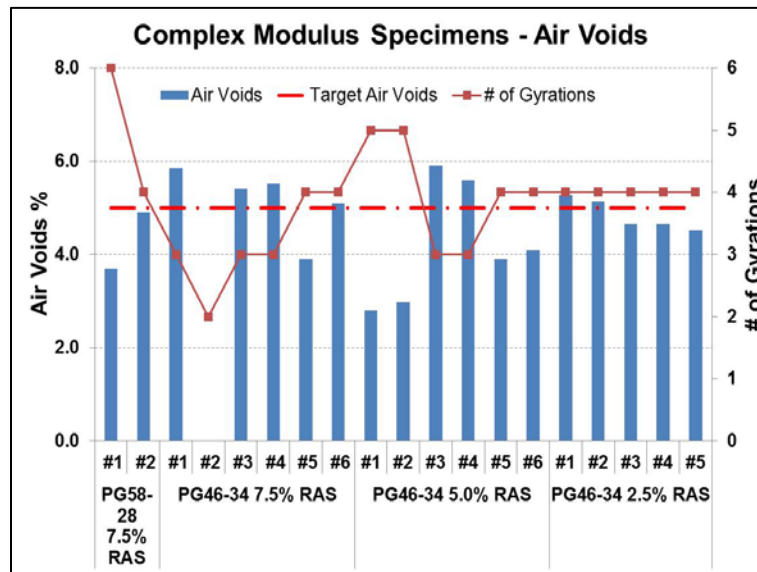

Figure 2. Air void distribution of all samples prepared for complex modulus testing along with number of gyrations required to achieve target density.

### 2.3.2 Hamburg Wheel Track Testing

The Hamburg wheel track test (WTT) is a test used to measure the rutting and moisture susceptibility of asphalt mixtures. The WTT machine is an electrically powered machine capable of moving a 203.2 mm (8.0 in) diameter, 47.0 mm (1.85 in) wide steel wheel over a test specimen. The wheel load is  $705.0 \pm 4.5$  N ( $158.0 \pm 1.0$  lb). The wheel passes about  $52 \pm 2$  passes per minute across the specimen at a speed of about 0.305 m/s (1 ft/sec).

Rutting is defined as the depth caused by movement of the WTT wheels after a specific number of passes. The WTT system records the displacement on 11 locations on the specimen at each wheel pass. Rutting curves can be produced using the data exported from the WTT system to characterize the increase in the specimen's rut depth with the increase in the number of passes while running the test. According to IDOT's recent revisions on the Hamburg wheel tracking test criteria, the number of passes is related to specified asphalt binder grade shown on the plans. With higher recycled materials (ABR over 20%), bumping in the grade of asphalt binder is necessary, which would result in PG 58-28 or PG 46-34 when the original grade is PG 64-22. Corresponding rut depth requirement in Hamburg test is 7,500 passes for the mixes specified with PG 64-22 or 5,000 passes for mixes specified with PG 58-28. In this study, the WTT specimens were prepared from 130.0 mm (5.1 in) gyratory-compacted samples. The 130.0 mm (5.1 in) specimens were cut in half and prepared to produce two specimens of about 62.5 mm (2.46 in) height each and 150.0 mm (5.9 in) in diameter. Available field cores from the mixes with PG 46-34 and PG 58-28, both with 7.5% RAS, were also tested using the WTT. The specimens were tested on the WTT at a bathwater temperature of 50°C (122°F) according to AASHTO T324-11 standards. Tests were continued to complete 20,000 wheel passes for all the mixtures. Test results with higher rut depths indicates that the mix has less rutting resistance while lower rut depths means that the mix has a better rutting resistance, Figure 3 shows the mold assembly to insert two specimens of 62.5 mm (2.46 in) height. Two molds containing four specimens at 62.5 mm (2.46 in) height are required to run the WTT. Plaster gypsum was used to fix the specimens on the molds. Figure 4 shows the WTT configuration.

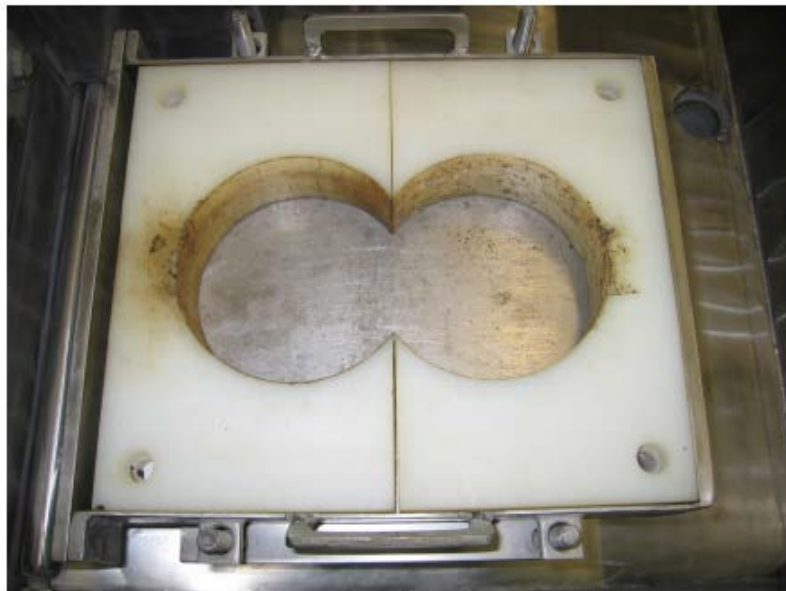

Figure 3. Mold assembly for wheel track testing.

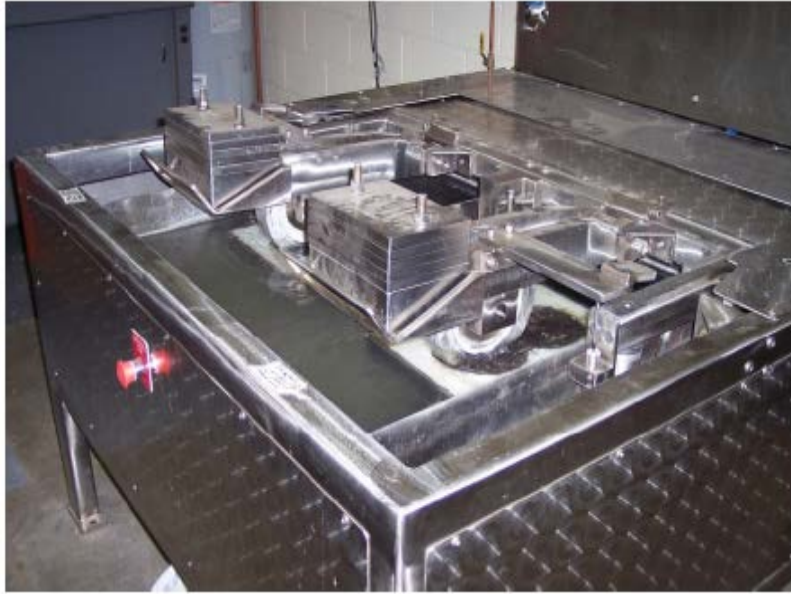

Figure 4. Wheel track test assembly with samples submerged in water at 50°C (122°F).

Figure 5 shows the number of replicates used with each mix for the WTT, along with the air voids for each replicate and the number of gyrations. It is important to note the difference in air voids of field cores compared to those of the lab-compacted samples.

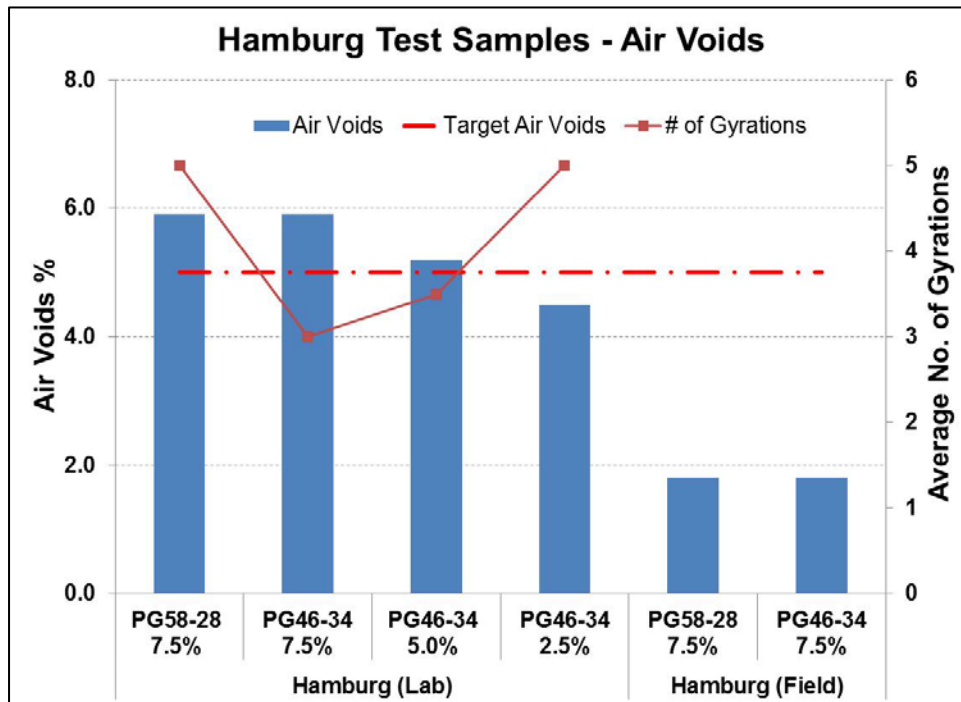

Figure 5. Distribution of air voids and number of gyrations for wheel track test samples.

### 2.3.3 Fracture Testing

Three fracture tests were performed in this study to evaluate the mixtures' fracture properties. The SCB tests were performed for each mixture and for the available field cores at  $-12^{\circ}\text{C}$  ( $10.4^{\circ}\text{F}$ ) and at  $0^{\circ}\text{C}$  ( $32.0^{\circ}\text{F}$ ). Two of the lab-compacted samples (the mixes with PG 46-34 and 5.0% RAS/35% FRAP and PG 46-34 and 7.5% RAS/37.5% FRAP) were tested using the DCT at  $-12^{\circ}\text{C}$  ( $10.4^{\circ}\text{F}$ ). In addition, the TTI overlay test was used to characterize the reflective cracking resistance of the lab-compacted samples at  $25^{\circ}\text{C}$  ( $77^{\circ}\text{F}$ ). A summary of each test follows.

#### 2.3.3.1 Semi Circular Bending Beam (SCB)

The SCB test is used to determine the fracture energy and fracture toughness of the asphalt mixtures at low temperatures. Fracture energy is defined as the area under the load-displacement curve. Displacements are represented by recording the crack mouth opening displacement (CMOD) using a clip-gage extensometer. The test is a strain-controlled test while the load is applied along the vertical diameter of the specimen to ensure a CMOD opening of about 0.70 mm/min (0.028 in/min) and to ensure stable crack growth conditions during the test. Fracture energy representations can be used to evaluate a mixture's resistance to pavement cracking and thermal cracking at lower pavement temperatures. Higher values of fracture energy indicate that the mix has increased resistance to thermal cracking at lower temperatures.

In this study, SCB tests were conducted at  $-12^{\circ}\text{C}$  ( $10.4^{\circ}\text{F}$ ) and  $0^{\circ}\text{C}$  ( $32.0^{\circ}\text{F}$ ) for lab-compacted samples and field cores. The SCB specimens were cut and prepared from the 180.0 mm (7.0 in) gyratory-compacted specimens. Each 180.0 mm (7.0 in) sample produced four semi-circles: two slices each at 50.0 mm (2.0 in) thick from the middle part of the specimen, as illustrated in Figure 6. Density measurements were conducted for each sample (semi-circle) separately. The available field cores from the mix with PG 46-34 and 7.5% RAS/37.5% FRAP and the mix with PG 58-28 and 7.5% RAS/37.5% FRAP mix were also tested. In addition, 1-year aged field cores from pavement sections constructed with mixes with PG 46-34 5.0% RAS/35% FRAP and 7.5% RAS/37.5% FRAP and the mix with PG 58-28 and 7.5% RAS/37.5% FRAP were obtained for additional fracture testing.

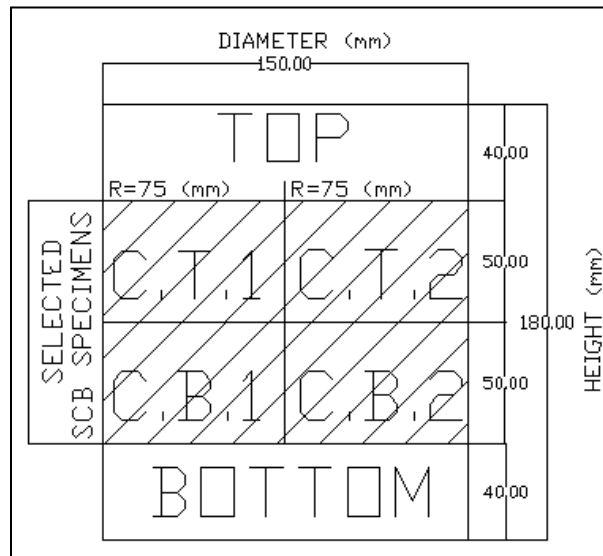

Figure 6. SCB slices cut from 180 mm (7.0 in) gyratory-compacted specimen (side view of the 180 mm (7.0 in) lab-compacted sample).

Figure 7 shows the SCB test fixture and testing chamber. Figure 8 and Figure 9 show the number of replicates used with each mix for the SCB, along with the air voids for each replicate and the number of gyrations at  $-12^{\circ}\text{C}$  ( $10.4^{\circ}\text{F}$ ) and  $0^{\circ}\text{C}$  ( $32^{\circ}\text{F}$ ), respectively.



Figure 7. Semi-circular bending beam (SCB) test fixture.

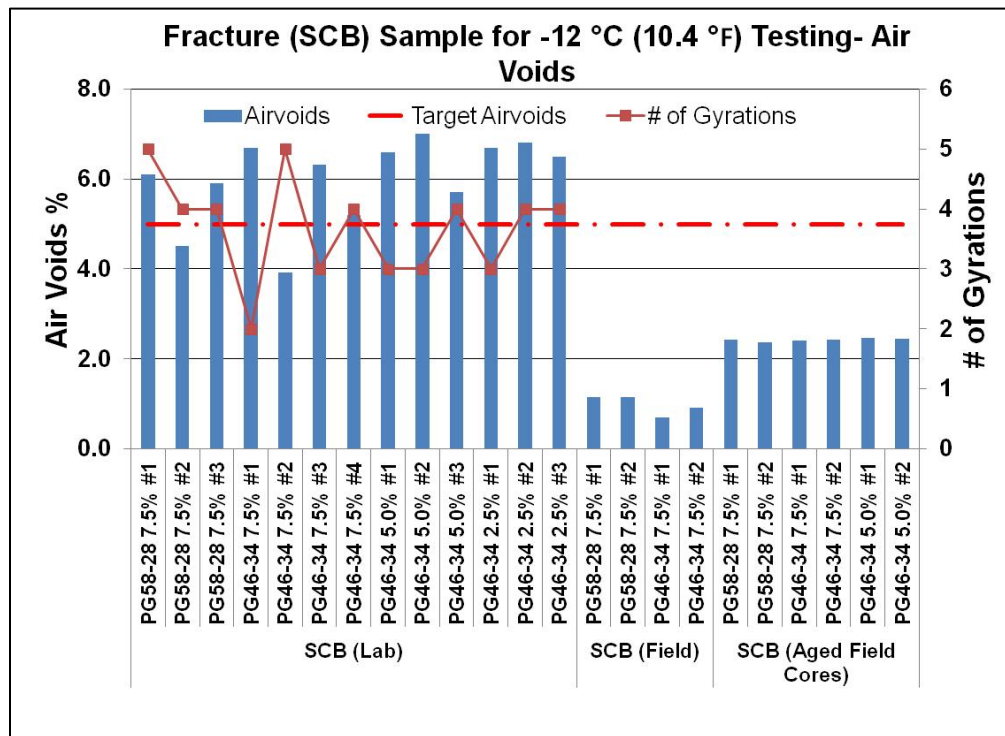

Figure 8. Distribution of air voids and number of gyrations for SCB test samples tested at  $-12^{\circ}\text{C}$  ( $10.4^{\circ}\text{F}$ ).

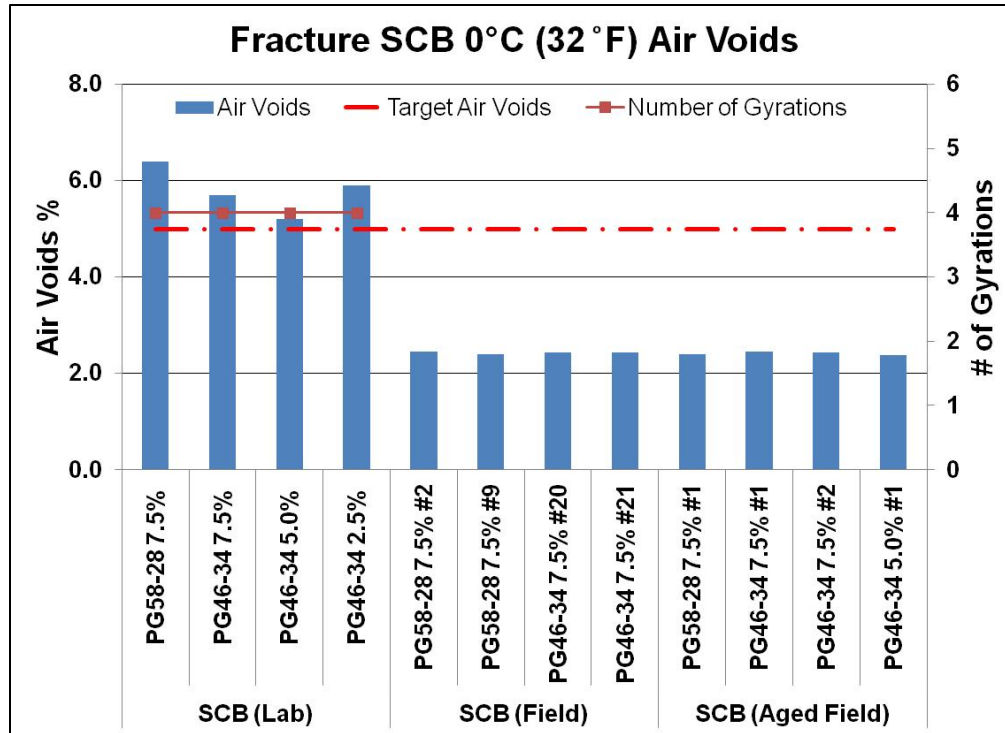

Figure 9. Distribution of air voids and number of gyrations for SCB test samples tested at 0°C (32°F).

### 2.3.3.2 Disc Compact Tension Test (DCT)

The disc compact tension test is used to measure and evaluate fracture energy and fracture properties of a disc-shaped asphalt concrete specimen. The DCT specimen is a circular specimen with a single edge notch that is loaded in tension to measure the load required to propagate the crack through the length of the specimen (ASTM D7313-07a). Similar to the SCB test procedure, fracture energy can be obtained by calculating the area under load and the CMOD curve recorded during the test. The DCT test is also strain controlled as the tension load is applied to ensure the specified CMOD opening throughout the specimen and to ensure stable crack growth throughout the specimen as well.

In this study, the DCT test was conducted on the mixes with PG 46-34 and 5.0% RAS/35% FRAP and 7.5% RAS/37.5% FRAP. The test specimens were prepared from the 180 mm (7.0 in) gyratory-compacted specimens, similar to sample preparation for the SCB sample preparation. Each 180 mm (7.0 in) specimen produces two DCT samples from the middle part of the 180 mm (7.0 in) sample, as illustrated in Figure 10. Density measurements were separately conducted on each disc-shaped specimen. Figure 11 shows the DCT test specimen and setup, while Figure 12 shows the number of replicates used for DCT test with each mix, along with the percentage of air voids and number of gyrations.



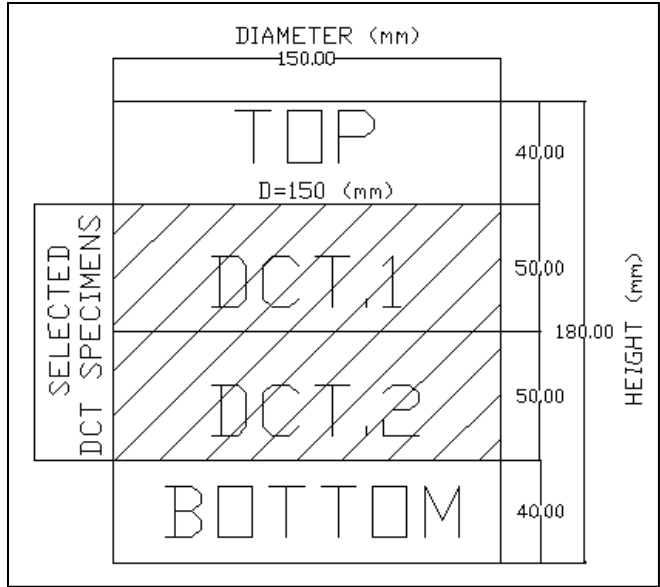

Figure 10. Slices cut from 180 mm (7.0 in) gyratory-compacted specimen for DCT testing (side view of the 180 mm (7.0 in) lab-compacted sample).

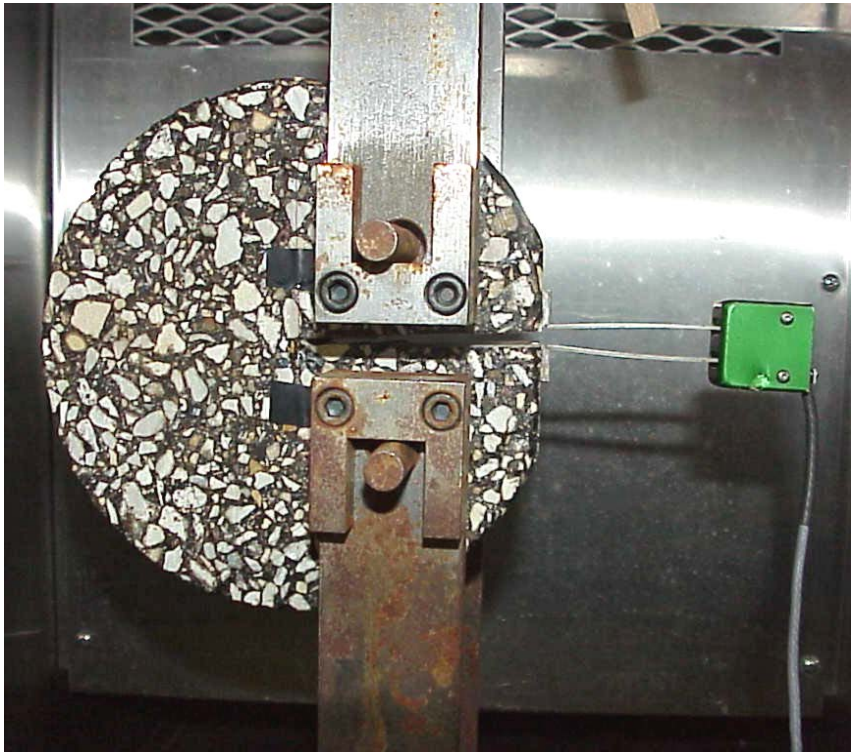

Figure 11. DCT test specimen and fixture.

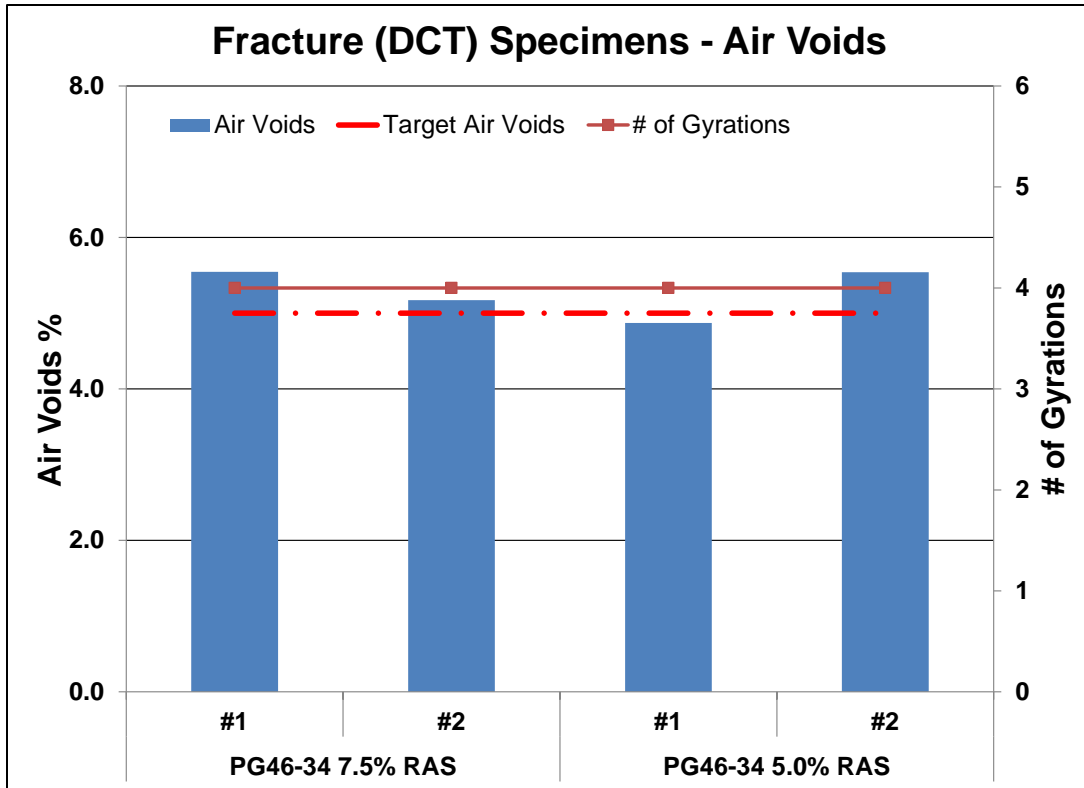

Figure 12. Distribution of air voids and number of gyrations for DCT test samples.

### 2.3.4 Fatigue Testing

#### 2.3.4.1 Texas Transportation Institute (TTI) Overlay Test

The TTI overlay test is a fatigue test that measures the reflective cracking resistance of asphalt pavements with the repeated application of cyclic displacements. The TTI overlay tester was designed by Robert Lytton and his co-workers in the late 1970s to simulate the opening and closing of joints or cracks, which are the main force inducing reflective crack initiation and propagation (Zhou 2005). To simulate the force caused by opening and closing of the joint on the TTI overlay tester, the specimen is fixed at the top of two steel plates, with one steel plate fixed and the other moving at 0.1 Hz cyclic loading in order to apply the load from the bottom of the specimen. The TTI overlay test is performed at 25°C (77°F), with an opening displacement of 0.635 mm (0.025 in).

Figure 13 and Figure 14 illustrate the test fixture and how the specimens were attached to the steel plates. In this study, overlay tests were performed for the lab-compacted specimens at the Texas Department of Transportation. Test samples were compacted at target air voids of 5.0%. Figure 15 shows the number of replicates and the percentage of air voids of each sample used in the tests.

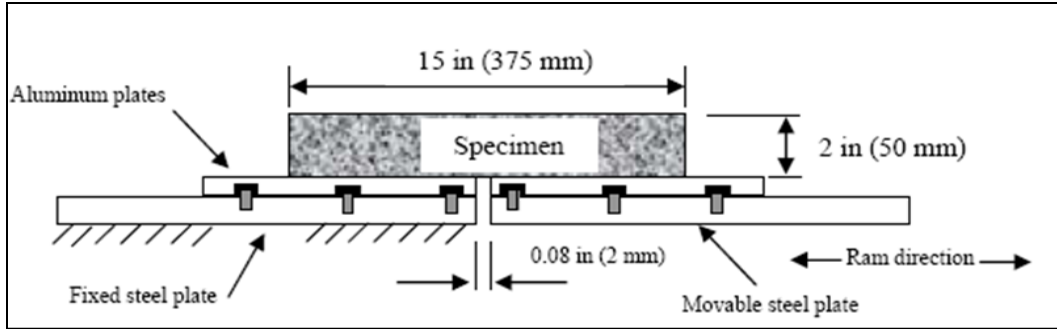

Figure 13. Two steel plates simulate the opening and closing of joints or cracks in old pavements beneath an overlay (Zhou 2005).

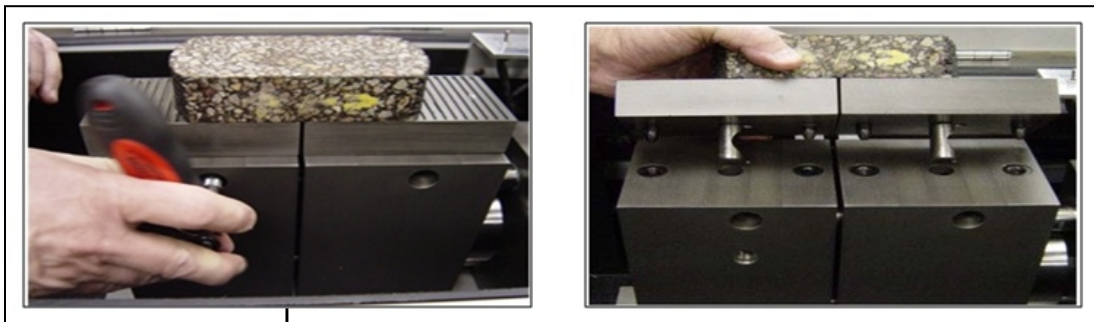

Figure 14. Specimen fixing on the steel plates of the TTI overlay tester (Zhou 2005).

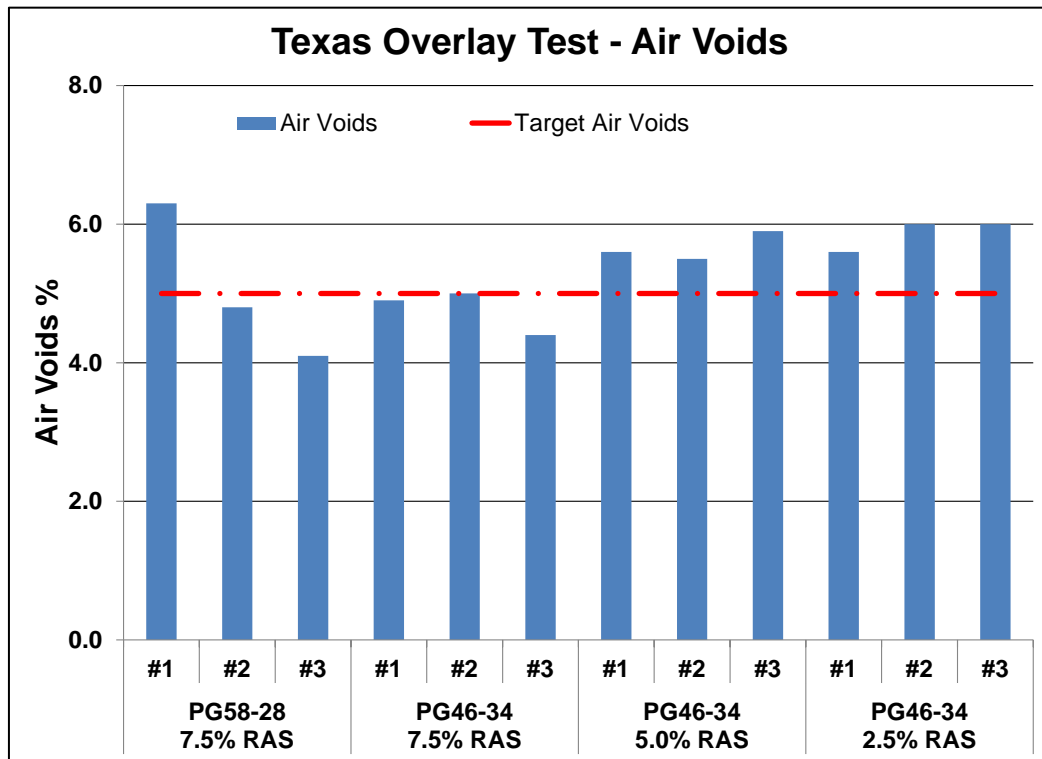

Figure 15. Air void distribution of samples tested with the overlay tester.

#### 2.3.4.2 Push-Pull Fatigue Test

The push-pull test is a fatigue test used to determine the continuum damage characteristics of the HMA. The test was developed by Kim and his co-workers to characterize damage in asphalt concrete specimens using a simple uniaxial test and continuum damage theories (Kim et al. 2008; Kim 2009). Damage characteristic curve parameters can be measured by applying controlled and repeated cyclic tension and compression loading to a cylindrical asphalt concrete specimen until failure. The damage characteristic curve is defined as the relationship between the damage parameter ( $S$ ) and the pseudo secant modulus ( $C$ ). The damage ( $S$ ) is the internal state variable that qualifies microstructural changes in the asphalt concrete mixture, and the pseudo secant modulus ( $C$ ) is the secant modulus in stress pseudo strain space. The damage characteristic curve can be used to analyze the fatigue characteristics of an asphalt concrete mixture. It can also be used in combination with additional pavement response models to predict fatigue behavior of asphalt concrete mixtures.

Due to limited resources, specimens in this study that had been previously prepared for complex modulus testing were also used for the push-pull fatigue test. The tests were performed for each mix at 20°C (68°F) and at 15°C (59°F) (for limited specimens) with a specified maximum strain limit of 250 microstrains and 150 microstrains, respectively, and a maximum of 100,000 cycles at a frequency of 10 Hz. The test was also performed for all the mixes at 20°C (68°F) and a maximum limit of 350 microstrains. Figure 16 shows the push-pull test setup. The specimens were glued to the top and bottom plates using a Devcon 10110 type glue.



Figure 16. An illustration of the push-pull test fixture and specimen glued to top and bottom plates.

## CHAPTER 3 RESULTS AND ANALYSIS

### 3.1 COMPLEX MODULUS TEST RESULTS

Complex moduli were measured and evaluated for the available mixtures with varying percentages of FRAP and RAS at different frequencies and at different temperatures. Table 4 shows the test matrix of the complex modulus tests performed in this study. Tests were not performed at 54°C due to strains exceeding the limits of displacement gages for some of the mixes. The results obtained during the temperature and frequency sweep tests were used to develop master curves, as shown in Figure 17. A reference temperature of 21°C was established. The results clearly indicate the influence of FRAP and RAS on the complex modulus results at high temperature and slow loading speeds (low reduced frequencies). The increase in complex modulus with increasing FRAP and RAS contents can be explained by the stiff and aged FRAP and RAS asphalt binder that replaced the virgin asphalt binder. The effect of reduction on the high temperature grade (bumping from PG 58-28 to PG 46-34) on complex modulus at this range of temperature and loading speed is also evident. Softer virgin asphalt binder resulted in smaller complex modulus values. On the other hand, low temperature or high loading speed response of FRAP/RAS mixes is not distinguishable.

Table 4. Complex Modulus Test Matrix

Test Temperature (°C)	Test Frequency (Hz)	Mixes
-10	0.1, 0.5, 1, 5, 10, 25	PG 46-34 and 2.5%RAS
4	0.1, 0.5, 1, 5, 10, 25	PG 46-34 and 5.0%RAS
21	0.1, 0.5, 1, 5, 10, 25	PG 46-34 and 7.5%RAS
38	0.1, 0.5, 1, 5, 10, 25	PG 58-28 and 7.5%RAS

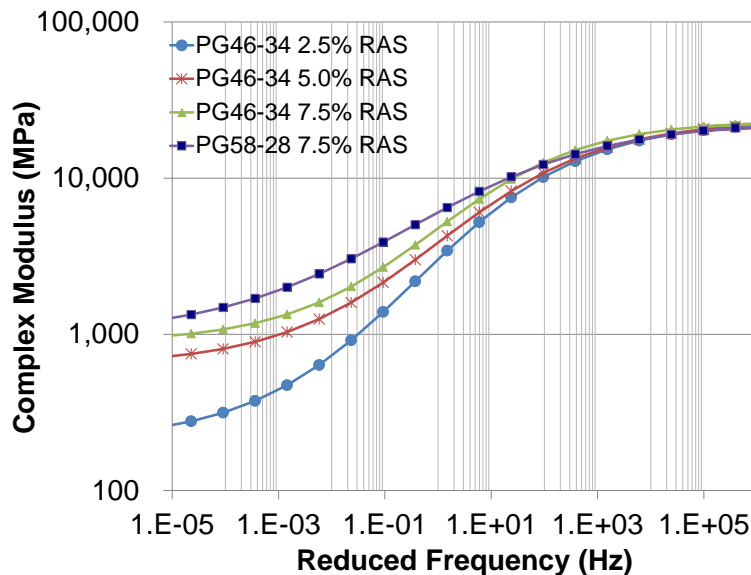

Figure 17. Master curves derived from complex modulus test results for mixes with varying percentages of RAS.

Since the mixes investigated in the study had extreme asphalt binder replacement values at such a low N-design, it is important to compare the modulus to other conventional mixtures with and without recycled materials. The FRAP/RAS mixes were compared to some of the mixes developed in two previous IDOT projects. Figure 18 illustrates the comparison of complex modulus results to those mixes. The mixes are 9.5-mm F-mix (with PG70-22), 12.5-mm SMA (with PG 76-22), and mixes with 30% and 50% RAP (with PG 58-22 and PG 58-28, respectively). The F-mix and SMA mixes are known to be durable surface mixes with N90 design. Because of the aggregate skeleton designed for these mixes (F-mix and SMA), complex moduli at low temperature and/or high loading speeds are much greater than those of RAS mixes, which are N30 design. However, the effect of FRAP/RAS is apparent at high temperature/low loading speeds (increased modulus). The presence of FRAP/RAS, even when using a much softer asphalt binder than used in the SMA and F-mix, increased the complex modulus considerably.

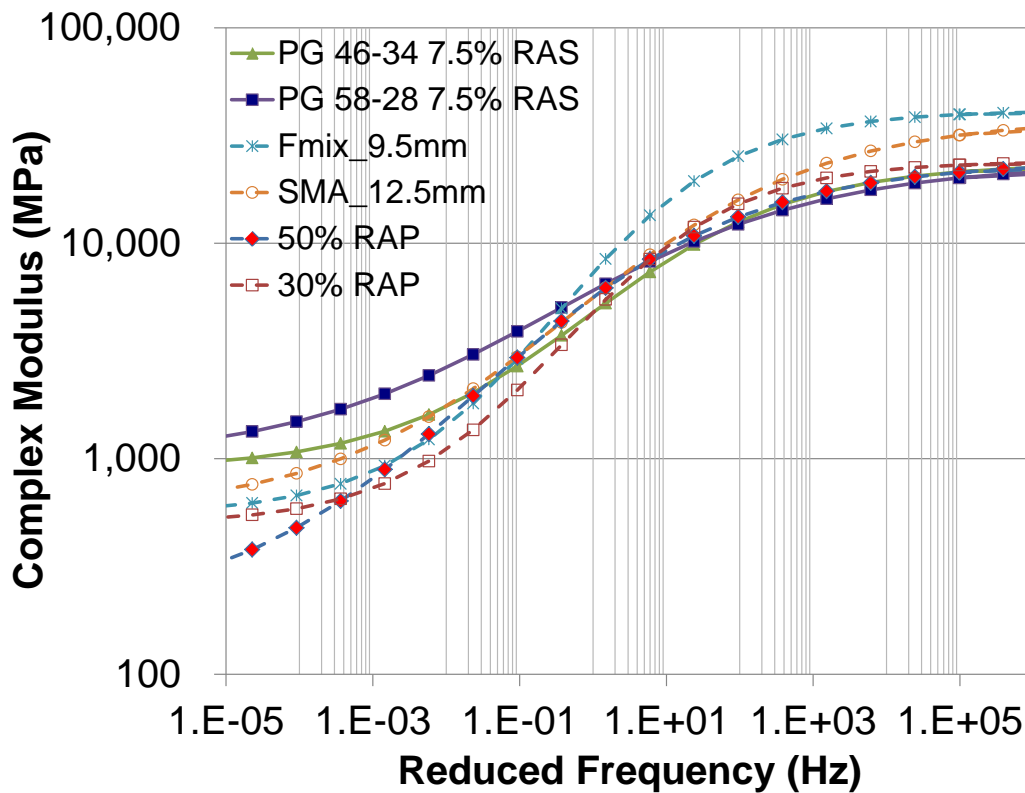

Figure 18. Complex modulus results for mixes with 7.5% RAS, compared to other conventional mixes.

There are some unique features of master curves that can explain viscoelastic material response. One of these parameters is the slope of master curves, which indicates how well the material can relax stresses. The slope of each curve presented in Figure 17 is calculated and illustrated in Figure 19. According to the results, the mix with PG 58-28 and 7.5% RAS and 37.5% FRAP has the smallest slope; hence, the smallest relaxation potential. On the other hand, the specimen with 2.5% RAS and 32.5% FRAP and PG 46-34 has the highest slope, indicating the greatest relaxation potential. The correlation between the slopes and fatigue tests is discussed in the following sections. The slope of some conventional mixes is also shown in the figure. Specifying the range of the optimal slope of

the master curve for a mix to have a good rutting resistance and thermal cracking resistance is beyond the scope of this study. However, this study points out the importance of mixes' relaxation potential. Further research is needed to investigate this with a wide range of mixes.

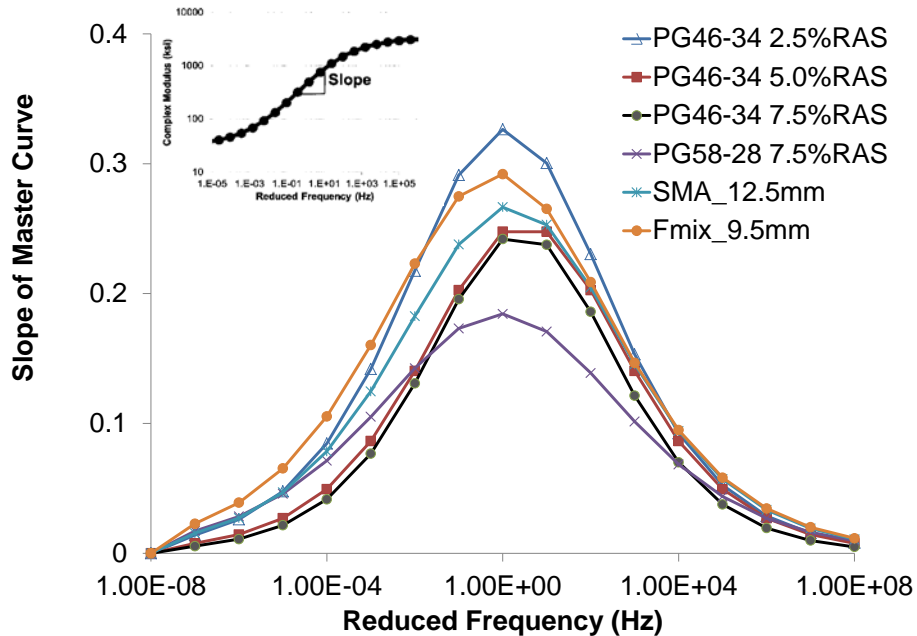

Figure 19. Slope of master curves for each mix indicating relaxation properties.

### 3.2 HAMBURG WHEEL TRACK TEST RESULTS

The wheel track tests were performed in this study on the available RAS mixes and field cores. Table 5 shows the test matrix, along with maximum deflection values at the end of 20,000 cycles.

Table 5. WTT Matrix, Volumetric Details, and Final Deflection

	Specimen ID	Average Air Voids	Number of gyrations	Final deflection (mm)
Lab Compacted	PG 58-28 7.5% RAS	5.9	5	3.8
	PG 46-34 7.5% RAS	5.9	3	5.1
	PG 46-34 5.0% RAS	5.0	3	5.9
	PG 46-34 2.5% RAS	4.5	5	12.8
Field Cores	PG 58-28 7.5% RAS	1.8	NA	3.5
	PG 46-34 7.5% RAS	1.8	NA	7.4

Figure 20 illustrates the effects of the RAS on each mix. According to the results, the mixes with increasing RAS percentage exhibited smaller permanent deformations. It can be concluded that the presence of aged asphalt binder improves rutting resistance for the mixture. The effect of the stiffer asphalt binder grade is also clear, as the mix with PG 58-28 was the lowest displacement mix among all mixes. It is also important that all of the mixes passed the IDOT criteria for mixes with PG 58-28 and lower grade asphalt binder (12.5 mm (0.49 in) at 5,000 or 7,500 passes depends on the final blended asphalt binder grade after replacing part of the virgin asphalt binder using RAS and FRAP). A comparison of field cores and lab-compacted specimens was also made. Figure 21 compares the test results obtained from these specimens. It is observed that the results for field cores and lab-compacted specimens are generally in agreement, even though field cores have considerably higher density, as shown previously in Table 5 and Figure 4. Pictures from the tested specimens are provided in Appendix A.

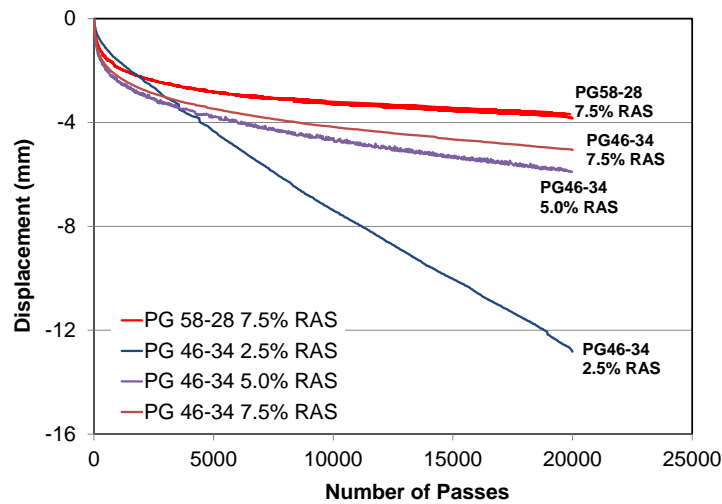

Figure 20. WTT results for the laboratory-compacted samples.

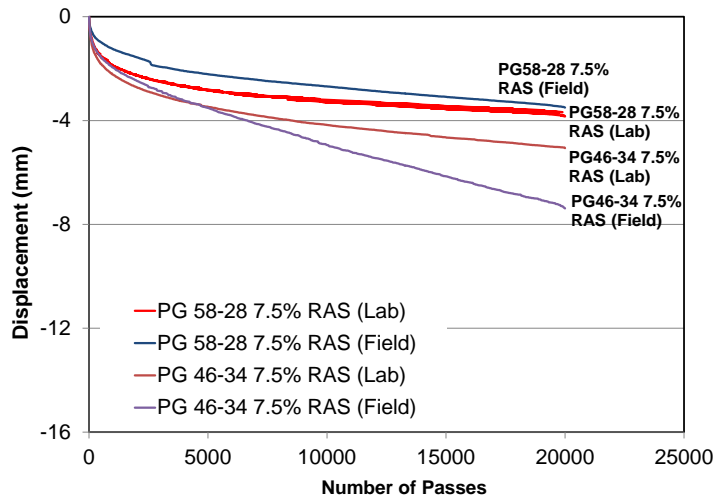

Figure 21. A comparison of wheel track test results for field cores and lab-compacted specimens.



### 3.3 FRACTURE TESTING RESULTS

The SCB and DCT fracture tests were performed on the available RAS mixes and field cores obtained shortly after construction and 1 year after construction. Fracture tests were conducted at two temperatures (0°C (32°F) and -12°C (10.4°F)). Fracture energy was calculated using crack mouth opening displacement and load results.

Figure 22 shows the SCB fracture energy results for lab-compacted specimens and for the field cores at -12°C (10.4°F). As indicated by the error bars in the figure, the results obtained from the lab-compacted specimens can be considered statistically insignificant. However, the following trends can be observed from the results presented in this figure. Both field cores (cores obtained shortly after construction and 1 year after construction) have higher fracture energy than that of lab-compacted specimens. The effect of RAS content was not evident in fracture energy values; however, the effect of asphalt binder bumping (from PG 58-28 to PG 46-34) on fracture energy is more evident. The presence of PG 46-34 brings an increase in fracture energy, indicating a potential to negate the effects of aged and stiff asphalt binder in the mixes.

Fracture tests conducted for lab-compacted specimens and field cores at 0°C (32°F) are shown in Figure 23. An increase in fracture energy is expected for fracture tests at increasing temperatures. The results obtained at 0°C (32°F) indicate an increase in fracture energy values for all of the mix types. It is evident from Figure 23 that fracture energy of field cores is significantly higher than that of lab-compacted mixes. This can be attributed to the effect of in-place air voids of field cores (1%–2%, compared to 5%–6%, as shown in Figure 9) manifested at elevated temperatures. The results also show an increase in fracture energy for mixes with 2.5% RAS, compared to the other lab-compacted mixes.

Figure 24 shows a comparison between the two types of fracture tests. Laboratory-compacted mixes with 5.0% RAS/35% FRAP and 7.5% RAS/37.5% FRAP were tested using SCB and DCT at -12°C (10.4°F). The differences between SCB and DCT tests are expected. It is important to note a similar indifference in fracture energy of mixes with 5.0% RAS/35% FRAP and 7.5% RAS/37.5% FRAP for the two types of fracture tests.

Figure 25 shows a comparison of SCB at -12°C (10.4°F) for the RAS mixes and some other conventional mixes used in the previous projects. The objective of this is just to check how the RAS mixes are behaving when compared to other conventional mixes.

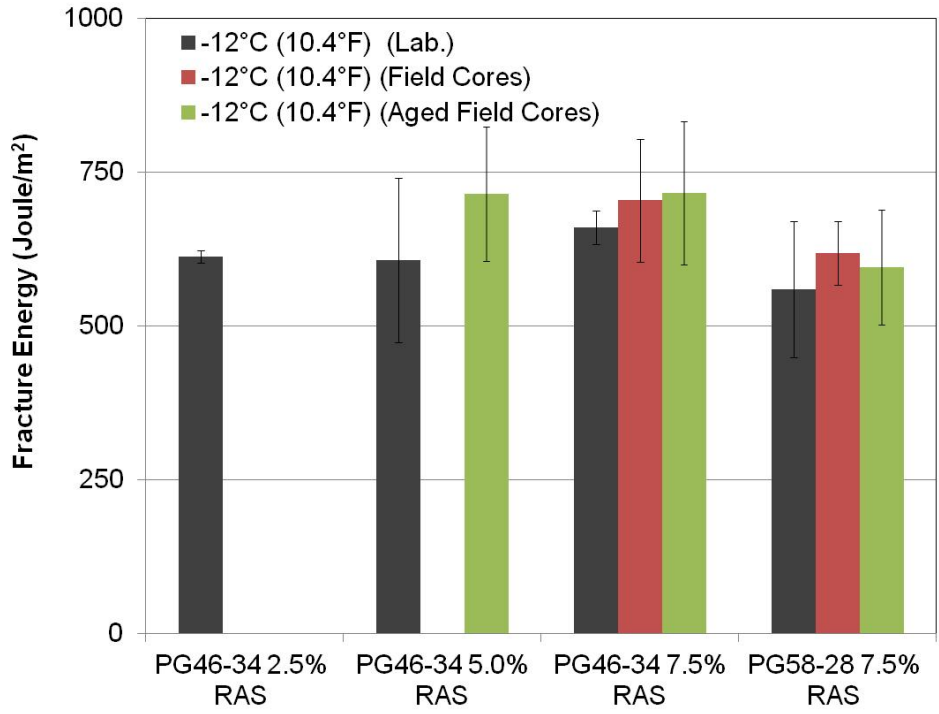

Figure 22. Fracture (SCB) test results of lab-prepared specimens and field cores at -12°C (10.4°F).

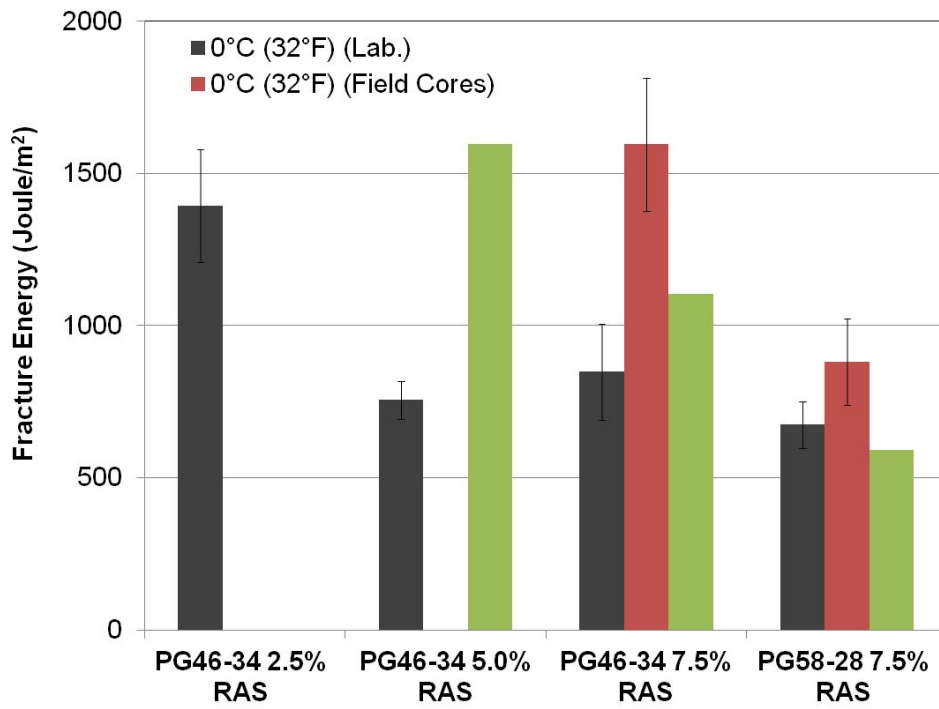

Figure 23. Fracture (SCB) test results of lab-prepared specimens and field cores at 0°C (32°F).

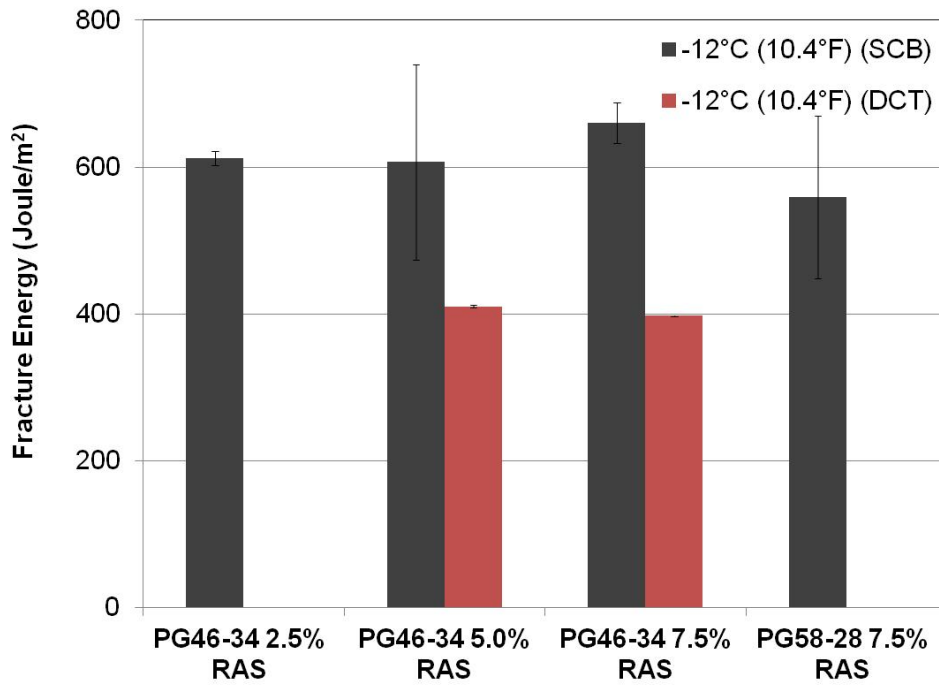

Figure 24. A comparison of fracture tests using SCB and DCT test methods.

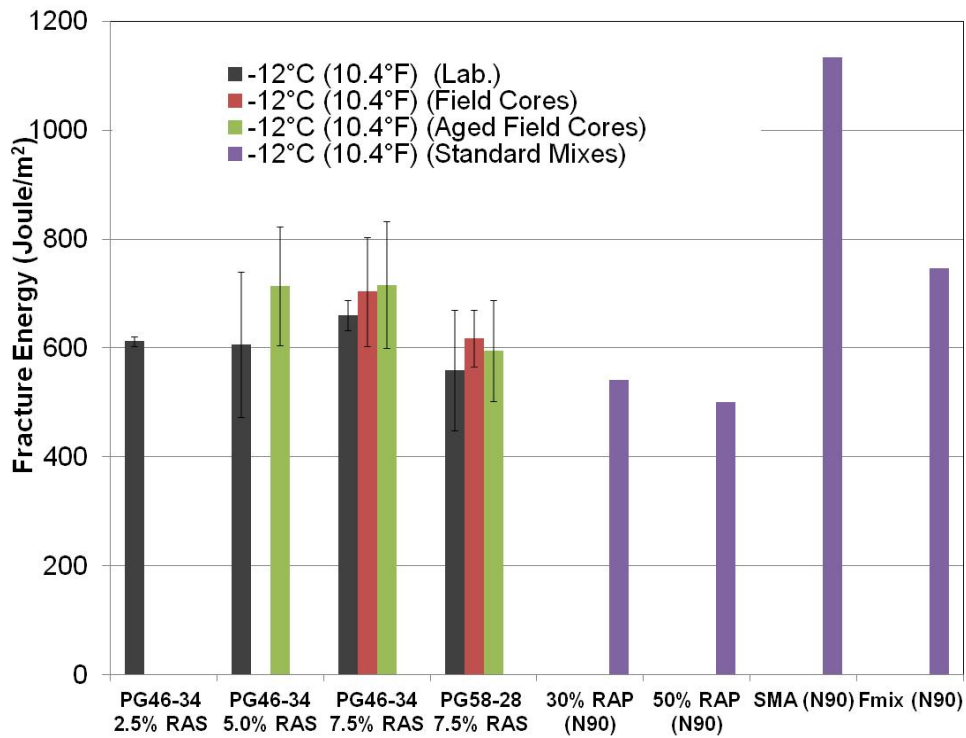

Figure 25. Fracture (SCB) test results of lab-prepared specimens and field cores compared to other standard mixes at  $-12^{\circ}\text{C}$  ( $10.4^{\circ}\text{F}$ )

### 3.4 FATIGUE TESTING RESULTS

#### 3.4.1 TTI Overlay Test Results

The TTI overlay tests were conducted for the lab-compacted mixes at Texas Department of Transportation facilities. Figure 26 illustrates the average number of cycles to failure for each tested mix and initial starting load. Cyclic displacements with 0.635 mm (0.025 in) amplitude and 10 Hz frequency were applied. Overlay test results show a significant difference between mixes with 2.5% RAS/32.5% FRAP and other mixes with a higher RAS percentage and asphalt binder replacement. The mixes with 2.5% RAS/32.5% FRAP were able to tolerate significantly more cycles than the other mixes. It is also important to note the increase in the initial applied loads, which can be attributed to the increase in stiffness of the mixes with increasing RAS percentage. This increase is also consistent with the complex modulus results shown in Figure 17.

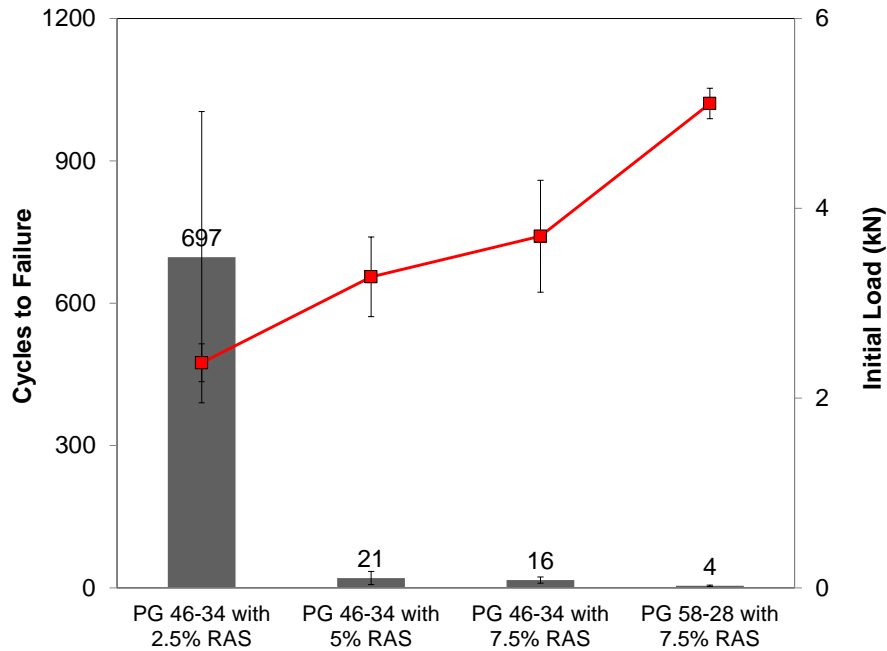

Figure 3. Overlay test results illustrating average number of cycles to failure and initial starting load.

#### 3.4.2 Push-Pull Test Results

The push-pull tests were performed on lab-prepared specimens at different temperatures and microstrain levels. The tests were performed in a displacement-controlled mode with a target on specimen strains. Table 6 shows the push-pull test matrix and conditions applied for each specimen. Test parameters were varied in order to obtain characteristic damage curves for each mix.

Table 6. Push-Pull Test Matrix

Sample ID	Number	Air Voids	# Gyration	Microstrain limit	Temperature (°C)
2.5% RAS PG 46-34	1	5.1	4	250	20
	2	4.7	4	350	20
	3	4.5	4	350	20
5.0% RAS PG 46-34	1	5.9	3	150	15
	2	3.0	5	250	20
	3	4.1	4	250	20
	4	2.8	5	350	20
	5	5.6	3	350	20
7.5% RAS PG 46-34	1	3.9	4	150	15
	2	5.1	4	250	20
	3	5.4	3	250	20
	1	5.8	3	350	20
	2	5.5	3	350	20
7.5% RAS PG 58-28	1	3.7	6	150	15
	1	4.9	4	250	20

Figures 27, 28, and 29 illustrate modulus degradation with application of each displacement cycle during the push-pull test at each testing condition. Modulus degradation is calculated by normalizing the value of modulus measured at each cycle by the initial modulus obtained. Modulus degradation curves indicate the rate of damage evolution (formation of microcracks and permanent deformation) until the specimen fully fails. The results at 15°C (59°F) (Figure 27) show that complete failure was achieved only for mixes with 7.5% RAS and 37.5% FRAP with PG 58-28. The specimens with PG 46-34 survived until the termination cycle (100,000) without noticeable damage. It is important to note that the specimen with 2.5% RAS was lost due to glue failure during the test. Therefore, no push-pull test results were reported for that mix.

When temperature and microstrain levels were increased, most of the specimens exhibited complete failure (Figure 28 and Figure 29). As shown in Figure 28, the specimens with 5.0% RAS/35% FRAP and higher and with PG 46-34 and PG 58-28 reached complete failure around 50,000 cycles. Two important observations seen in this figure are the performances of 2.5% RAS with PG 46-34 and 7.5% RAS with PG 58-28. Similar to the results obtained at 150 microstrain and 15°C (59°F), the specimen with PG 58-28 reached failure at a much faster rate than all other specimens. On the other hand, the specimen with PG 46-34 and 2.5% RAS and 32.5% FRAP performed the best at this temperature and microstrain level.

Lastly, microstrain levels were increased to 350 at 20°C (68°F); the results are shown in Figure 29. Under this test condition, all of the specimens failed before approximately 25,000 cycles, but the specimen with 2.5% RAS/32.5% FRAP provides the least modulus degradation.

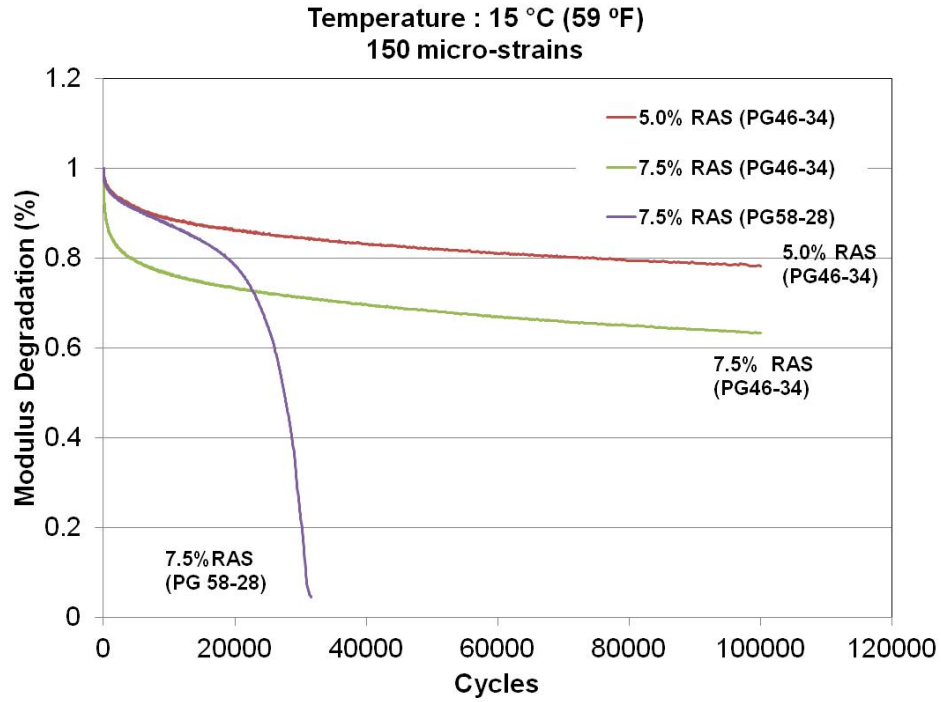

Figure 27. Push-pull test modulus degradation at 150 microstrains and 15°C (59°F) test temperature.

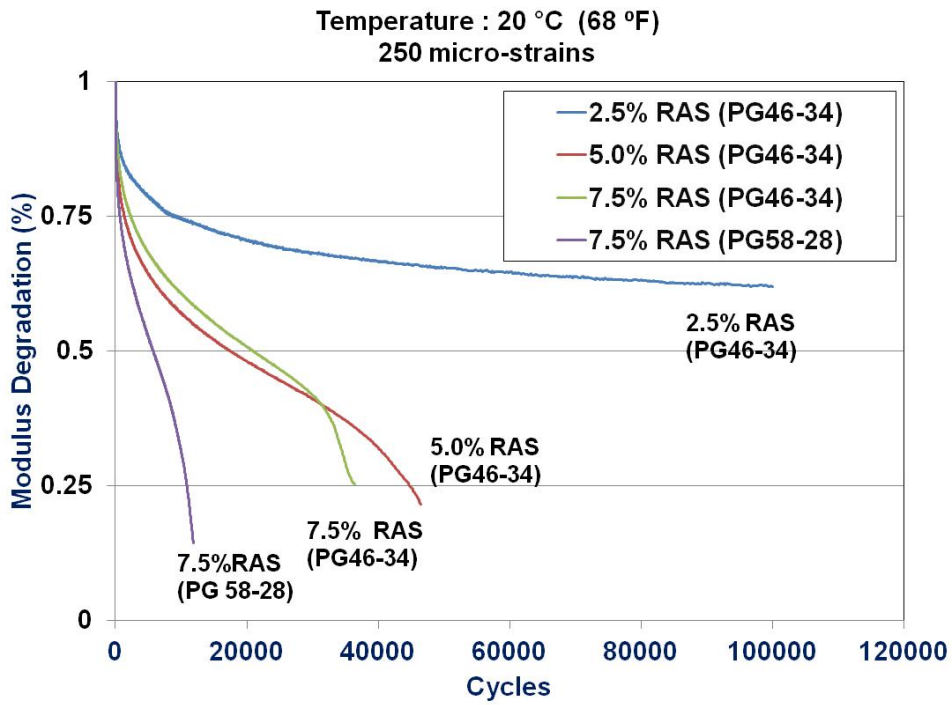

Figure 28. Push-pull test modulus degradation at 250 microstrains and 20°C (68°F) test temperature.

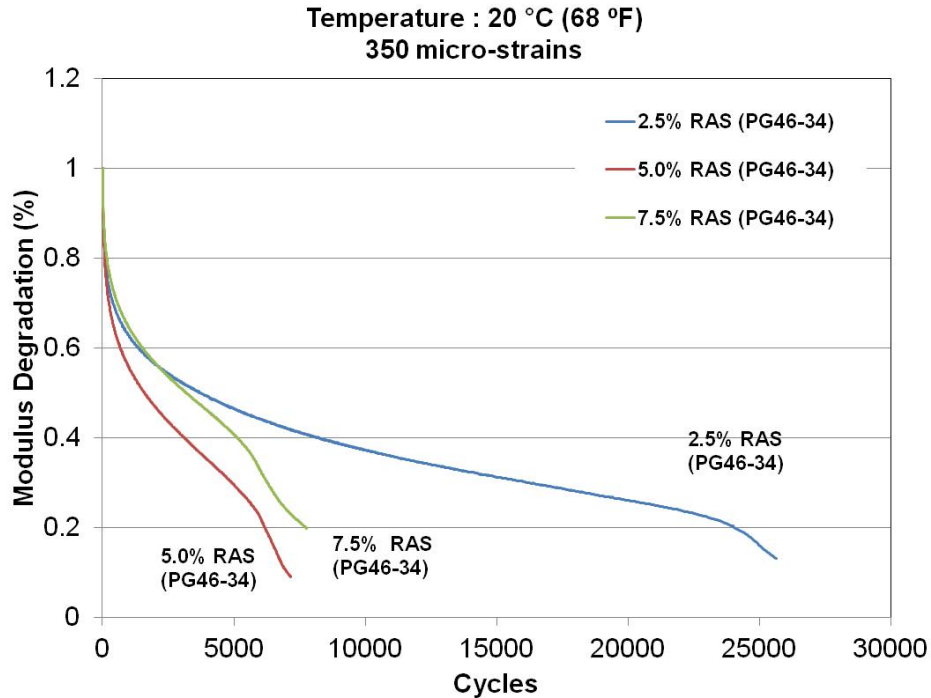

Figure 29. Push-pull test modulus degradation at 350 microstrains and 20°C (68°F) test temperature.

Another way to assess push-pull results can be done by defining the 50% reduction in complex modulus failure criteria that is recommended for flexural fatigue testing (AASHTO TP8-64). The number of cycles to reach 50% reduction modulus is captured from the results presented in Figures 27, 28, and 29. The results are shown in Figures 30, 31, and 32. Based on the results presented from the push-pull test results, the following observations can be made:

- 2.5% RAS with PG 46-34 required the higher number of cycles to reach 50% modulus reduction.
- The specimens with PG 58-28 showed the worst performance. This can be considered a validation of the importance of double-double bumping, especially for mixes with high asphalt binder replacement. However, it is important to note that the specimens prepared for the mixes with PG 58-28 were limited to one replicate due to limited availability of loose mixes. It is crucially important to repeat these tests with additional replicates.
- There is not much difference between the specimens with 5.0% and 7.5% RAS.

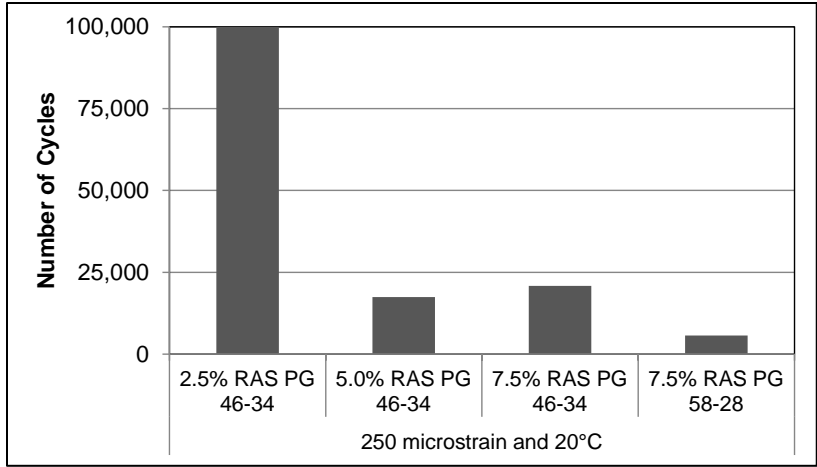

Figure 30. Number of cycles to failure at 50% modulus degradation at 250 microstrain and 20°C (68°F).

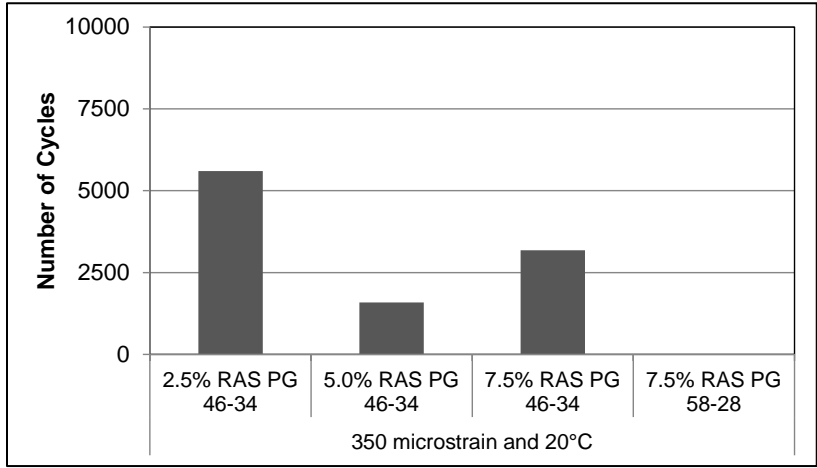

Figure 31. Number of cycles to failure at 50% modulus degradation at 350 microstrain and 20°C (68°F).

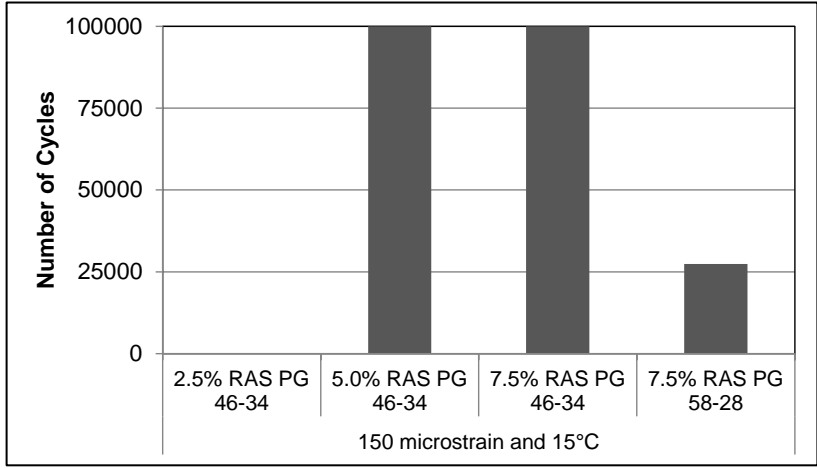

Figure 32. Number of cycles to failure at 50% modulus degradation at 150 microstrain and 15°C (59°F).



Fatigue test results (TTI overlay and push-pull) demonstrate the difference between the mixes with PG 58-28 and PG 46-34. In addition, it is observed that the mix with 2.5% RAS and PG 46-34 (43% asphalt binder replacement) also has significantly different fatigue performance. A correlation can be made to the slopes of master curves presented Figure 19. The bigger the slope, the higher the relaxation potential of mixes, which can help in fatigue loading stages. Figure 33 illustrates the correlation between slope and number of cycles to failure in push-pull and TTI overlay tests. These figures indicate a very strong relationship between slope and number of cycles to failure.

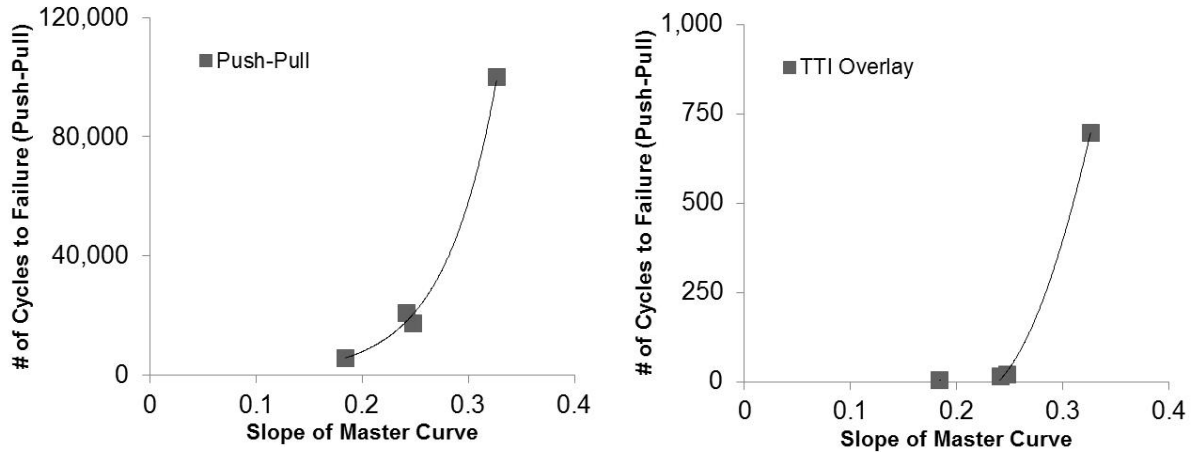

Figure 33. Correlation between slope and number of cycles to failure in push-pull (left) and TTI overlay tests (right).

## CHAPTER 4 SUMMARY AND CONCLUSIONS

In this study, the effect of using RAS and FRAP on one type of asphalt mixture was studied in an experimental program that included permanent deformation, stiffness, fracture, and fatigue tests. Below is a summary of the experimental findings from this study:

- Rutting or Permanent Deformation : Mixtures with various percentages of RAS and two asphalt binder grades were evaluated using the wheel track test to determine the mixtures' resistance to rutting or permanent deformation. The use of RAS clearly improved resistance to rutting or permanent deformation at a higher pavement temperature. It was also shown that high temperature grade bumping (from PG 58-28 to PG 46-34) to compensate for the presence of RAS in the mix did not adversely affect rutting resistance.
- Low-Temperature Cracking : The fracture energy for the mixtures with various percentages of RAS was evaluated at  $-12^{\circ}\text{C}$  ( $10.4^{\circ}\text{F}$ ) and  $0^{\circ}\text{C}$  ( $32^{\circ}\text{F}$ ) using the semi-circular bending beam test (SCB) and the disc compact tension test (DCT). Field cores and lab-compacted specimens were tested. There was no clear difference observed for lab-compacted specimens at  $-12^{\circ}\text{C}$  ( $10.4^{\circ}\text{F}$ ) for any level of RAS. However, field cores at the same temperature had slightly greater fracture energy than that of lab-compacted specimens. On the other hand, fracture energy tests at  $0^{\circ}\text{C}$  ( $32^{\circ}\text{F}$ ) revealed significant differences in lab-compacted specimens (indicating the influence of RAS) and between lab and field cores. Fracture energy of specimens with 2.5% RAS was significantly higher than for the other lab-compacted specimens. In addition, the effect of asphalt binder grade was found to affect fracture energy of mixes with 7.5% RAS. Compared to lab-compacted specimens, field cores had considerably higher fracture energy, possibly due to the increasing influence of low air voids at milder temperatures.
- Fatigue Performance Against Reflective Cracking at Intermediate Temperatures : The RAS mixtures were evaluated using the TTI overlay tester, which proposed as a device predicting mixtures' resistance to reflective cracking. It was found that the increase in the percentage of RAS in the mixes combined with the use of stiffer asphalt binder grade (PG 58-28) significantly reduced a mixture's resistance to the applied displacement cycles.
- Stiffness via Complex Modulus : The complex modulus of asphalt mixtures can potentially indicate performance parameters such as permanent deformation resistance or fatigue life. It was shown that as the amount of RAS increases in the mixes, significant changes to the master curves (complex modulus as a function of temperature-time) were observed. The increase in RAS resulted in significant increases in modulus at high temperature and/or low loading speeds. In addition, the slope of master curves, which can be considered an important indicator of the relaxation potential of asphalt mixtures, decreased (indicates lower relaxation) with increasing RAS in the mixes. Stiffness at high temperatures and slope of master curves are related to permanent deformation resistance and fatigue life of mixtures, respectively.
- Fatigue Life and Damage Characterization : Limited number of push-pull fatigue tests was conducted on the mixes. Degrading complex moduli were also evaluated using the push-pull fatigue test to predict damage and fatigue life of asphalt mixtures. It was found that an increase in the percentage of RAS or use of stiffer asphalt binder grade with a higher percentage of RAS clearly increases

the rate of damage evolution in the specimens; hence, it accelerates a material's modulus degradation.

The main concern with increasing use of RAS in asphalt mixtures is the potential adverse effects on fracture and fatigue performance of mixes. Different types of fatigue and fracture experiments were conducted to assess this hypothesis. The results obtained from various types of performance-related experiments show that monotonic fracture experiments at low temperatures may not be used alone to evaluate the mixes with high percentages of recycled materials, which can potentially exhibit more brittle fracture. The increase in tensile strength of these mixes with addition of aged stiff asphalt binder may compensate for the effect of brittleness on fracture energy values.

On the other hand, fatigue tests where cyclic stress or displacements are applied were able to differentiate among mixes with various percentages of RAS at intermediate temperatures 15°C–25°C (59°F–77°F) based on the results obtained from limited fatigue tests. Both of the fatigue tests yielded similar results to demonstrate the effect of various percentages of RAS in addition to the effect of asphalt binder type. The benefits of using a softer grade for mixes with high asphalt binder replacement were highlighted in the results of push-pull tests. As the amount of RAS in a mix increased from 2.5% to 5.0% and 7.5% (from 43% to 64% asphalt binder replacement), fatigue performance deteriorated.

In addition to fracture and fatigue tests, it was also shown that a fundamental test such as complex modulus can be used as a tool to estimate fatigue performance of brittle mixes. It was shown that the complex modulus test results can provide important information about viscoelastic properties of mixes, such as relaxation potential and long-term stiffness. The slope (indicating relaxation potential) and long-term stiffness values can be used together with fracture tests to evaluate mixes with high asphalt binder replacement.







In conclusion, this study highlights the impact of one type and source of RAS with FRAP on fatigue, fracture, and permanent deformation resistance of a low N-design asphalt mixture. According to the results obtained from the experimental program, the specimens prepared with 2.5% RAS and PG 46-34 showed better performance than the other RAS mixes used in this study. The impact of asphalt binder bumping was highlighted by the results of all tests. The mixes with PG 58-28 had the lowest fracture energy (indicating higher cracking potential), the lowest number of cycles to failure consistently with the two types of fatigue tests, and distinctive complex modulus results. The improvement in fatigue performance and fracture energy was noticeable when the asphalt binder type was changed from PG 58-28 to PG 46-34 at the highest asphalt binder replacement level. Therefore, aggressive binder bumping (the use of PG 46-34 replacing original design asphalt binder PG 64-22) is warranted for the mixes with high asphalt binder replacement levels. According to the preliminary information obtained from the experimental program, laboratory performance of the asphalt mixture tested in this study at increasing levels of RAS when they are used with an appropriate asphalt binder grade is promising. However, additional fatigue and fracture tests are needed to determine low and medium temperature cracking susceptibility of the mixes at the high asphalt binder replacement levels.

## REFERENCES

- AASHTO TP 8-64 "Method for determining the fatigue life of compacted hot-mix asphalt (HMA) subjected to repeated flexural bending." AASHTO Provisional Standards, May 2002.
- Al-Qadi, I.L., Q. Aurangzeb, S. H. Carpenter, W. J. Pine, and J. Trepanier. 2012. "Impact of High RAP Content on Structural and Performance Properties of Asphalt Mixtures" Report No. ICT-R27-31. Rantoul, IL: Illinois Center for Transportation.
- Al-Qadi, I.L., S. H. Carpenter, G. L. Roberts, H. Ozer, Q. Aurangzeb, M. A. Elseifi, and J. Trepanier, 2009. "Determination of Usable Residual Asphalt Binder in RAP." Report No. ICT-R27-11. Rantoul, IL: Illinois Center for Transportation.
- ASTM. "Standard Test Method for Determining Fracture Energy of Asphalt-Aggregate Mixtures Using the Disk-Shaped Compact Tension Geometry." ASTM D 7313-07a: 1-7.
- Asphalt Institute. 1989. Hot-Mix Recycling, The Asphalt Handbook MS-4.
- Brownlee, M. 2011. "Utilization of Recycled and Reclaimed Materials in Illinois Highway Construction in 2010." Illinois Department of Transportation Bureau of Materials and Physical Research. Report No 160.
- Bukowski, J.R. 1997. "Guidelines for the Design of Superpave Mixtures Containing Reclaimed Asphalt Pavement (RAP)." Memorandum, ETG Meeting, FHWA Superpave Mixtures Expert Task Group, San Antonio, TX.
- Button J. W., D. Williams, and J. A. Scherocman. 1996. "Roofing Shingles and Toner in Asphalt Pavements." Research Report 1344, Research Study no. 0-1344, Texas Transportation Institute, The Texas A&M University System.
- Daniel, J. S., and A. Lachance. 2005. "Mechanistic and Volumetric Properties of Asphalt Mixtures with RAP." Journal of the Transportation Research Board 1929: 28–36.
- Gardiner, M. S., and C. Wagner. 1999. "Use of Reclaimed Asphalt Pavement in SuperPave Hot-Mix Asphalt Applications." Journal of the Transportation Research Board 1681:1–9.
- Goh, S. W., and Z. You. 2011. "Evaluation of recycled asphalt shingles in hot mix asphalt." 1st Congress of the Transportation and Development Institute of ASCE. In , 638-645. Department of Civil and Environmental Engineering, Michigan Technological University, Houghton, MI 49931, United States: American Society of Civil Engineers (ASCE).
- Kim, Y. R. 2009. "One-Dimensional Constitutive Modeling of Asphalt Concrete". Journal of Engineering Mechanics. Vol. 116 (4).
- Kim, Y. R., C. Baek, B. S. Underwood, V. Subramanian, M. N. Guddati, and K. L.. 2008. "Application of Viscoelastic Continuum Damage Model Based Finite Element Analysis to Predict the Fatigue Performance of Asphalt Pavements." KSCE Journal of Civil Engineering 12 (2): 109-120. doi:10.1007/s12205-008-0109-x.
- Kutay, M. E., N. Gibson and J. Youtcheff. 2008. "Conventional and Viscoelastic Continuum Damage (VECD) - Based Fatigue Analysis of Polymer Modified Asphalt Pavements." Journal of the Association of Asphalt Paving Technologists, 77.
- Li, X., Marasteanu, M. O., Williams, R. C., and Clyne, T. R. 2008. "Effect of Reclaimed Asphalt Pavement (Proportion and Type) and Binder Grade on Asphalt Mixtures." Journal of the Transportation Research Board 2051:90–97.

- McGraw, J., A. Zofka, D. Krivit, J. Schroer, R. Olson, and M. Marasteanu. 2007. "Recycled asphalt shingles in hot mix asphalt." *Journal of the Association of Asphalt Paving Technologists*, 76, pages 235.
- McDaniel, R., and R. M. Anderson. 2001. "Recommended Use of Reclaimed Asphalt Pavement in the SuperPave Mix Design Method: Technician's Manual." NCHRP Report 452, Washington, DC.
- Mogawer, W. S., A. J. Austerman, R. B., and M. Roussel. 2011. "Performance Characteristics of Thin-Lift Overlay Mixtures." *Transportation Research Record* (2208): 17-25. doi:10.3141/2208-03. <http://dx.doi.org/10.3141/2208-03>.
- Newcomb, D., M. Stroup-Gardiner, B. W., and A. Drescher. 1993. "Influence of Roofing Shingles on Asphalt Concrete Mixture Properties." Vol. 93-09. St. Paul, MN.
- Shah, A., R. S. McDaniel, G. A. Huber, and V. L. Gallivan. 2007. "Investigation of Properties of Plant-Produced Reclaimed Asphalt Pavement Mixtures." *Journal of the Transportation Research Board* 1998:103-111.
- Tao, M., E. Mahmoud, and H. U. Bahia. 2010. "Estimation of reclaimed asphalt pavement binder low-temperature properties without extraction: Development of testing procedure." *Transportation Research Record* (2179): 58-65. doi:10.3141/2179-07. <http://dx.doi.org/10.3141/2179-07>.
- Zhou, F. and T. Scullion. 2005. "Overlay Tester: A rapid performance related to crack resistance test." Research Report 1344, Research Study no. 0-44670-2, Texas Transportation Institute, The Texas A&M University System.

**APPENDIX A PHOTOS OF WHEEL TRACK TEST SAMPLES AFTER TESTING**

<b>WTT Samples</b>	
	
<b>PG 46-34 2.5% RAS</b>	<b>PG 46-34 5.0% RAS</b>
	
<b>PG 46-34 7.5% RAS</b>	<b>PG 58-28 7.5% RAS</b>
	
<b>PG 46-34 7.5% RAS (Field Cores)</b>	<b>PG 58-28 7.5% RAS (Field Cores)</b>

# APPENDIX B MIXTURE DESIGN AND MATERIALS GRADATION

DOT Lab Verification No.  Ver. 7.0-01.14.10 DATE:

Producer Number & Name  Plant Location

Material Code Number

Plant Site #	05	04	03	02	01	SP	RAP #3	RAP #2	RAP #1	ASPHALT
Site	042CM11			030FM23	027F002		017CM1304	017F0406	017F0406	10126
Source (PROD #)	0011326			00115-04	00119-09		0230-02	0230-02	0016-01	1702-01
(NAME)	Vulcan			Shuff City	Shuff City		Reliable/Ogden	Reliable/Ogden	Southern	Seneca
(LDC)	McCook			Orwest	Perfall		Pulaski	Pulaski	PAO	Lewist
(ADD. INFO)							4.7	6.1	26.5	19.25 +AC to RAP
Aggregate Blend	30.0	0.0	0.0	12.0	10.0	0.0	20.0	17.0	7.5	100.0

Lab Preparing Design   
Designing Lab Staff   
Designing Lab Name

App. No.	05	04	03	02	01	SP	RAP #3	RAP #2	RAP #1	Aggregate Blend	Mixture Comp. Spec
1" (25.0mm)	100.0	100.0	100.0	100.0	100.0	100.0	100.0	100.0	100.0	100.0	100
3/4" (19.0mm)	90.0	100.0	100.0	100.0	100.0	100.0	100.0	100.0	100.0	94	90-100
1/2" (12.5mm)	40.0	100.0	100.0	100.0	100.0	100.0	100.0	100.0	100.0	82	50-90
3/8" (9.5mm)	15.0	100.0	100.0	100.0	100.0	100.0	98.0	100.0	100.0	75	
No. 4 (4.75mm)	5.0	100.0	100.0	44.1	100.0	100.0	58.0	92.2	51.8	53	40-60
No. 8 (2.36mm)	4.0	100.0	100.0	5.0	32.0	100.0	26.0	60.0	91.0	29	
No. 16 (1.18mm)	4.0	100.0	100.0	4.0	71.0	100.0	28.0	88.0	71.0	29	15-40
No. 30 (60µm)	3.0	100.0	100.0	3.0	43.0	100.0	22.0	50.0	43.0	21	
No. 60 (300µm)	3.0	100.0	100.0	3.0	17.0	100.0	16.0	33.0	43.0	14	
No. 800 (150µm)	3.0	100.0	100.0	3.1	5.7	100.0	5.0	14.3	26.0	9	
No. 200 (75µm)	2.8	100.0	100.0	2.7	1.9	100.0	6.0	10.2	17.7	4.8	0-12

Min. Sp. Gr.	2.649	2.690	2.690	2.611	2.600	2.600	2.660	2.640	2.600	2.627	2.650
Absorption, %	1.72	1.06	1.06	2.20	1.90	1.80	1.99	1.00	1.00	1.31	1.04
									SP OR AC	1.026	

AMOUNT OF AGED RAP AC   
VRGIN AC

### SUMMARY OF SUPERPAVE GYRATORY DESIGN DATA

BITUMINOUS MIXTURE AGED  HOURS @

DATA for Tests	0	1	2	3	4	5	6	7	8	9
MIX 0	0.0	2.327	2.490	15.1	35.3	50.0	50.0	40.0	4.84	1.44
MIX 2	0.0	2.365	2.480	6.0	16.4	27.2	12.20	6.00	1.87	
MIX 3	7.0	1.374	2.480	47.2	66.0	12.0	7.10	4.71	1.29	
MIX 4	7.0	2.325	2.429	4.4	15.5	26.4	14.17	6.26	1.34	

DATA for 0.075	0	1	2	3	4	5	6	7	8	9
MIX 0	0.0	2.792	2.490	5.5	14.7	21.3	10.80	4.40	2.720	1.44
MIX 2	0.0	3.036	2.458	1.0	16.0	32.0	12.01	6.00	2.712	1.07
MIX 3	7.0	2.424	2.450	1.0	14.8	32.0	13.49	6.71	2.724	1.38
MIX 4	7.0	2.420	2.429	0.0	15.0	31.0	14.79	6.20	2.723	1.34

DESIGN OF	WMA	WMA	WMA	WMA	WMA	WMA	WMA	WMA	WMA	WMA
OPTIMUM DESIGN DATA @ 100°C	0	0.0	3.414	2.484	2.0	14.3	26.0	2.724	2.607	0.00

REMARKS LINE 1

REMARKS LINE 2

Tested by:

Reviewed by:

Verified by:

Final Approval:

TSR Information

Conditioned

Unconditioned

YDR

CA Strip Reten

FA Strip Reten

Additive Prod #

Additive Mat Code

Additive %

SW11001

